

Doc: ETD 13 (6211)

भारतीय मानक

Indian Standard

**DATA EXCHANGE FOR ELECTRICITY METER
READING, TARIFF AND LOAD CONTROL —
COMPANION SPECIFICATION**

ICS

© BIS 2010

**BUREAU OF INDIAN STANDARDS
MANAK BHAVAN, 9 BAHADUR SHAH ZAFAR MARG
NEW DELHI 110002**

APRIL 2010

Price Group

Equipment for Electrical Energy Measurement, Tariff and Load Control Sectional Committee, ET 13

FOREWORD

This Indian Standard was adopted by the Bureau of Indian Standards after the draft finalized by the Equipment for Electrical Energy Measurement, Tariff and Load control Sectional Committee (ET13) had been approved by the Electrotechnical Division Council.

With development of electronic meters having possibilities of metering data being integrated into business processes of service providers and in turn with generating agencies, thus opening up multiple opportunities in power system management at both micro and macro levels and being guided by the National Electricity Policy of the Central Government after enactment of the Electricity Act 2003, the Committee initiated the work of formulating standards on Data Exchange for Electricity Metering Equipment in 2006.

Two options were taken up for interoperable use of meters in a data network. In 2007, the Committee decided to adopt the International Standard IEC 62056 already available in various parts. However it was felt that only adoption was not sufficient for proper implementation as the selective features of the standard available at that time were not adequate for use by different utilities collectively. In view of urgent power reforms programme of the Central Government and the metering data integration involved, the Electrotechnical Division Council in April 2008, while appreciating the other option of Common Framework based solution being developed by Indian Electrical and Electronics Manufacturers Association (IEEMA), advised the committee and divergent stakeholders for rapid implementation of the IEC standard available. The Committee inducted experts and held a series of meetings for evolving this Indian Standard for proper implementation of the IEC standard based on open protocol and wide ranging selective features thereof, for application in Indian networks.

The Central Electricity Authority (CEA), a body under the Electricity Act 2003 to prepare regulations on installation and operation of meters and to record data regarding electricity from generation to utilization and the Central Power Research Institute, a Society under the Central Government, with established conformance test facilities for meters conforming to IEC62056 at its Bangalore Laboratory, both members of the Committee, were involved in preparation of category wise comprehensive list of metering parameters for use in national networks. The Report titled “Standardization of Metering Parameters” finalized with object identifier codes as requested was submitted to BIS in April 2009 for facilitating preparation of Indian Standards / Guides on Metering data exchange.

Distribution Line Message Specification (DLMS) with functionalities of Companion Specification for Energy Metering (COSEM) based on open protocols and maintained by Device Language Message Specification User Association, DLMS UA, Geneva, in the form of four technical Reports, namely “Blue”, “Green”, “Yellow” and “White” Books,

have been adopted by IEC on regular basis in the international standards mentioned above for interoperable use of electricity meters in a data network. The continuous development of DLMS / COSEM open communications protocols for data retrieval, updation, and reconfiguration of metering devices, has enabled diverse operators to access safely and quickly data from metering equipment provided by diverse manufacturers.

This Indian Standard, a Companion Specification in the form of a Guide, is intended to provide a field level basis for efficient and secure transfer of electricity metering data in an open manner with judicious application of features and protocols of the International Standard.

This Companion Specification refers to latest updates of Interface classes and OBIS codes available in 9th edition (2009) of the Blue Book of DLMS UA, This also refers to updates of procedures and services available in 7th edition (2009) of the DLMS UA Green Book. These revised Technical Reports of DLMS UA, considered as pre-standards for several parts of IEC 62056, will be adopted by IEC in due course and subsequently by BIS in adopted Indian standards being published. Till such time these books, accessible by members of DLMS User Association in India, may be referenced as IEC pre-standards. Contact details of these members can be found at - <http://www.dlms.com/organization/listofmembers/index.html>.

In the formulation of this standard assistance has been derived from the following International Standards:

<i>International Standard</i>	<i>Title</i>
DLMS UA 1000-1 ed.9, 2009	Blue book, COSEM Identification System and Interface Classes
DLMS UA 1000-2 ed.7, 2007	Green book, DLMS/COSEM Architecture and Protocols
DLMS UA 1002: ed.1, 2003	White book, COSEM Glossary of Terms
DLMS UA 1001-1:2007 ed-3	Yellow Book, Companion Testing Process
IEC 62056-61 Ed 2.0 (2006-11)	Electricity metering : Data exchange for meter reading, tariff and load control Object identification system (OBIS)
IEC 62056-62 Ed 2.0 (2006-11)	Electricity metering : Data exchange for meter reading, tariff and load control Part 62: Interface classes
IEC 62056-53 Ed 2.0 (2006-	Electricity metering : Data exchange for meter

12)	reading, tariff and load control Part 53: COSEM application layer
IEC 62056-46 Ed.1.1 (2002-07)	Electricity metering : Data exchange for meter reading, tariff and load control Part 46: Data link layer using HDLC protocol
IEC 62056-42 Ed.1.0 (2002)	Electricity metering : Data exchange for meter reading, tariff and load control Part 42: Physical layer services and procedures for connection-oriented asynchronous data exchange
IEC 62056-21 Ed 1.0 (2005-08)	Electricity metering : Data exchange for meter reading, tariff and load control Part 21: Direct local data exchange
IEC/TR 62051-1 Ed 1.0 (2004-01)	Electricity metering : Data exchange for meter reading, tariff and load control - Glossary of terms Part 1: Terms related to data exchange with metering equipment using DLMS/COSEM
NIST Special Publication 800-38D, Nov 2007	Recommendation for Block Cipher Modes of Operation: Galois/Counter Mode (GCM) and GMAC
NIST Federal Information Processing Standards Publication 197: Nov 2001	Advanced Encryption Standard (AES)
IETF Request For Circulation (RFC) - 3394: Sept, 2002.	Advanced Encryption Standard (AES) Key Wrap Algorithm (Informative)
NIST Federal Information Processing Standards Publication 199: 2004	Standards for security categorization of federal information and information systems

While writing this Specification it has been endeavored not to contradict on principle IEC 62056 and the DLMS/ COSEM updates on which it is based. However, in case of any divergence/ disparity, not amounting to conflict of interpretations that may be revealed later, provisions of this specification will prevail.

The abbreviations used in the standard are given in Annex L (see also IEC/TR 62051-1)

For the purpose of deciding whether a particular requirement of this standard is complied with, the final value, observed or calculated, expressing the result of a test or analysis, shall be rounded off in accordance with IS 2: 1960 'Rules for rounding off numerical values(*revised*)'. The number of significant places retained in the rounded off value should be the same as that of the specified value in this standard.

*Indian Standard***DATA EXCHANGE FOR ELECTRICITY METER
READING, TARIFF AND LOAD CONTROL —
COMPANION SPECIFICATION****1 SCOPE**

1.1 This standard is intended for use as companion to IEC 62056 series of standards on “Electricity Metering – Data Exchange for Meter Reading, Tariff and Load Control”, adopted from various parts of IEC62056.

1.2 These generic metering data exchange standards based on DLMS/ COSEM open protocols and features, provide a coverage for structured modeling of metering functionalities as available at communication interface(s), with procedures for identification of these data objects by mapping into respective codes, and finally for direct local exchange or remote exchange of these data messages by transporting over various layers of communication channels with specified procedures and services, as applicable.

1.3 This Companion Specification provides guidelines, specifies optional DLMS / COSEM elements and outlines boundary requirements for design of such DLMS / COSEM compliant electricity meters for possible applications in Indian electricity networks (*see* also Annex B). Such selections may involve:

- a) COSEM interface classes, their instances, attributes and methods to be supported, Event and Status tables, identified objects, DLMS services, Communication media and protocol stacks.
- b) Requirements for Direct Local Data Exchange involving HHU (MRI) and remote data exchange with HOST Computer (*see* also Annex J).
- c) The necessary country / project specific codes, not documented by DLMS UA, are included in Annex for specified usage of electricity meters.

1.4 The following are outside the scope of this Specification and will be decided by user/ manufacturer/ system integrator:

- a) Host computer – Metering equipment connectivity
- b) Compatible modem (Data Communication Equipment) and its requirements for chosen communication medium

c) Values and distribution methods of secret keys

1.5 Metering functions are outside the Scope of this specification and are covered by prevailing Indian standards as applicable.

2 REFERENCES

The following standards contains provision, which through reference in this text constitutes provision of this standard. At the time of publication, the editions indicated were valid. All standards are subject to revision and parties to agreements based on this standard are encouraged to investigate the possibility of applying the most recent editions of the standard indicated below:

<i>IS No.</i>	<i>Title</i>
IS14697	ac static transformer operated watt-hour and var-hour meters, class 0.2 S, 0.5 S and 1.0 S - specification

3 TERMINOLOGY

3.1 The following definitions are additional to those found in IEC/TR 62051-1, and are useful for this Companion Specification.

3.1.1 *Network*

A data communications system that allows a number of devices to communicate with each other. It indicates interconnection of these devices in a way concordant with the communications profile selected. It does not necessarily mean a diverse or wide-ranging set of connections, nor any routing capability. (*see also* 13.23 of IEC 62051)

3.1.2 *Architecture*

Overall requirement and application of the communication network, indicating structure and hierarchy. (*see also* 4.3 of IEC 62051)

3.1.3 *Object*

A collection of characteristic attributes and specified methods.

3.1.4 *Object modelling*

A technology independent model of a meter can be represented by a list of objects as seen through an interface and provides controlled access to their attributes and methods. The

data objects related to metering functionalities and parameters can be mapped into identifier codes forming a message for transportation according to an open protocol.

3.1.5 *Access point*

A physical interface point used to transfer data from/ to the meter network. It may be a gateway from a LAN to a higher order network or an interface to temporary reading equipment such as a HHU (MRI), a portable PC etc. (*see also* 4.2 of IEC 62051)

3.1.6 *Hand-Held Unit(HHU)*

A portable device for reading and programming equipment or meters at the access point. (*see also* 4.19 of IEC 62051)

3.1.7 *Meter Reading Instrument*

These are synonymous with HHU. (*see also* Annex G-1.7 & G- 1.8 of IS 14697)

3.1.8 *Configuration*

Setting of measurement and communication parameters to operate the meter correctly. (*see also* 4.7 of IEC 62051)

3.1.9 *Protocol*

The rules for communications system operation that must be followed if communication is to be effected (e.g. for meter reading and programming)(*see also* 13.72 of IEC 62051).

3.1.10 *Open Protocol*

The rules for communications system operation suitable for meter reading and limited programming of meters and data collection equipment of different types and from different manufacturers through open standardized documents (e.g. DLMS/ COSEM) (*see also* 3.1.65 of IEC 62051-1).

3.1.11 *Interface*

A point or means of interaction between two systems (e.g. between a meter and a data collection equipment) (*see also* 13.50 of IEC 62051).

3.1.12 *Parameter*

A single identifiable metering or other quantity which may be read or altered within meter readings, tariffication, or control and may have multiple aspects such as its value, scaling, timestamp, etc.

3.1.13 *Parameterization*

Setting of those parameters that define the configuration of the metering device, which implies writing values of COSEM object attributes. The parameterization tool can be seen as a special client

3.1.14 *Data Concentrator*

A device used to hold the data from a number of meters, in a way that identifies the data from each meter, and allows it to be accessed in real time by a higher-level data collector. Typically a concentrator is accessed in a manner similar to the meters, but supports faster or cheaper communication, and has greater storage capacity, than is available with the meters themselves. (An example of use is to concentrate data from a number of electrical distribution substations).

3.1.15 *Host Computer*

A computer system to which data collected by HHUs is returned for processing, and /or which can collect data remotely from a meter or data concentrator.

3.1.16 *Data Encryption*

The changing of the form of a data stream in such a way that only the intended recipient can read or alter the information and unauthorised messages may be detected. It ensures data security (*see also* 13.29 of IEC 62051).

3.1.17 *Key*

Transforms a particular message using an algorithm to make it unreadable to anyone except the recipient, to preserve integrity, authenticity and confidentiality of the message or vice versa, through a standardised procedure.

3.1.18 *Confidentiality*

Preserving authorized restrictions on information access and disclosure, including means for protecting personal privacy and proprietary information. A loss of confidentiality is the unauthorized disclosure of information

3.1.19 *Integrity*

Guarding against improper information modification or destruction, and includes ensuring information non-repudiation and authenticity. A loss of integrity is the unauthorized modification or destruction of information.

3.1.20 *Open Systems Interconnections(OSI)*

A framework for communication processes in which the process is divided into seven functional layers, arranged one above the other with each having a separate responsibility. Each layer communicates with the layer immediately above and below it (*see also* 12.4 & 12.1 of IEC 62051)

3.1.21 *Collapsed Architecture*

A subset of the OSI reference model which consists of only three layers: Physical layer, Data link layer and Application layer.

3.1.22 *Layer*

One of seven functional entities within the OSI model (normal and collapsed architecture) as given in Table 1 below (*see also* 12.2 of IEC 62051).

Table 1 OSI model- Functional layers
(*Clause 3.1.22*)

SI.No	Layer	Normal	Collapsed
(1)	(2)	(3)	(4)
i)	7	Application	Application
ii)	6	Presentation	–
iii)	5	Session	–
iv)	4	Transport	–
v)	3	Network	–
vi)	2	Data-link	Data-link
vii)	1	Physical	Physical

3.1.22.1 *Physical layer (OSI layer 1)*

That layer of the OSI reference model which provides bit transmission between one node and the next, physical interfacing with media, data signal encoding and defines electrical parameters, connector size, shape and pinouts.

3.1.22.2 *Data link layer (OSI layer 2)*

That layer of the OSI reference model which performs and controls specified transmission service functions by means of a link protocol.

3.1.22.3 *Network layer (OSI layer 3)*

That layer of the OSI reference model which establishes the source to destination path across the network, switches, routes and controls congestion of information packets.

3.1.22.4 *Transport layer (OSI layer 4)*

That layer of the OSI reference model which provides reliable transmission of layer 7 messages end-to-end across the communication network.

3.1.22.5 *Session layer (OSI layer 5)*

That layer of the OSI reference model which establishes and terminates end-to-end sessions, provides process synchronization, and determines if half-duplex or full-duplex is to be used.

3.1.22.6 *Presentation layer (OSI layer 6)*

That layer of the OSI reference model which establishes the syntax (form) in which data is exchanged.

3.1.22.7 *Application layer (OSI layer 7)*

That layer of the OSI reference model which provides end –user services such as file transfers, electronic messages and remote data base access.

3.1.23 *Conformance Testing*

Planned and regulated process of evaluation of a type of metering equipment in order to gain confidence about implementation of declared features of this Specification and generic standards IEC 62056 in that particular type, by a laboratory authorized for the purpose. (*see also* Annex H).

4 ARCHITECTURE

4.1 The typical connectivity scheme between a meter (SERVER) and the CLIENT, considered for this specification, is shown in Fig. 1.

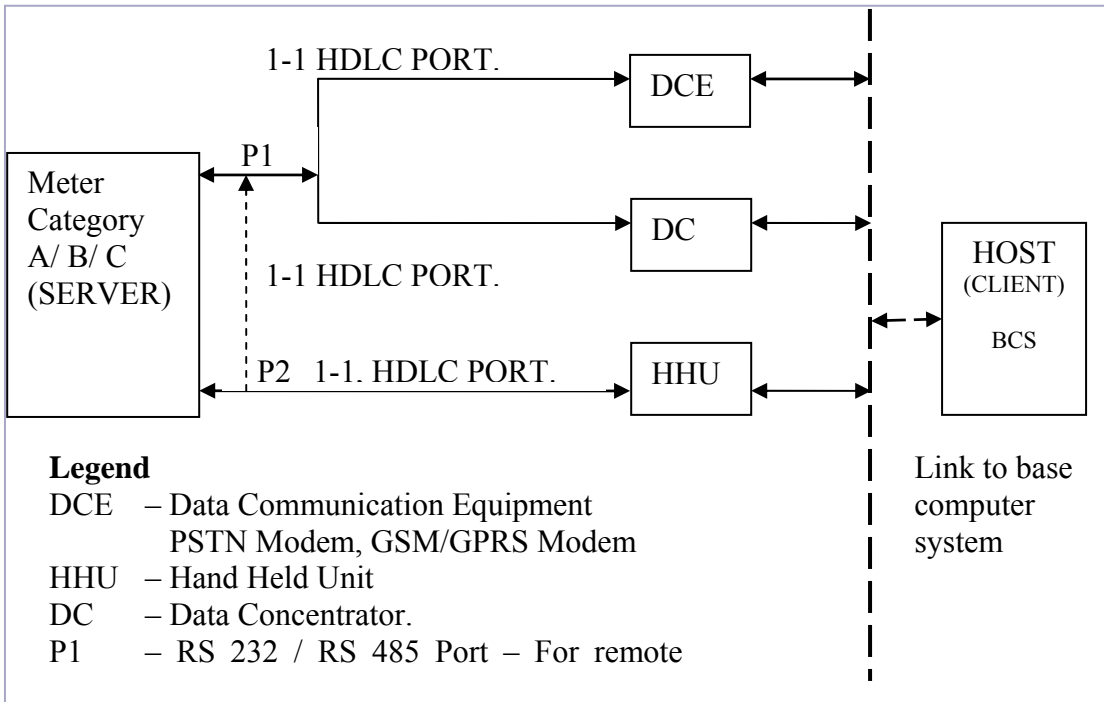

Fig. 1 MESSAGE FLOW CONNECTIVITY SCHEME BETWEEN METER/ SERVER AND CLIENT.

4.2 Physical Requirements

The meter (server) shall support a minimum of two ports for data communication, as given below:

- a) P1 – An Electrical port compatible with RS 232 or RS 485 specifications. This shall be used for remote access from the HOST (CLIENT) or DC (CLIENT).
- b) P2 – An Optical port complying with hardware specifications detailed in IEC-62056-21. This shall be used for local access from a HHU (MRI).
- c) The P1 and P2 both shall support the 3-layer Connection Oriented COSEM/HDLC profile, with a minimum and default baud rate of 9600.
- d) Both P1 and P2 shall support 4 byte and one byte addressing both. HHU can read from either port.

The optical port is not required to support any mode of IEC-62056-21, that is, mode of usage shall be direct HDLC (*see also* Fig. 1).

4.3 Requirements for Simultaneous Operation

The meter (server) is not required to allow more than one association to be open at any one time. Optical port shall have priority when both ports are accessed simultaneously. This means that if the electrical port is connected and being accessed for data, any attempt to connect on optical port shall cause the connection on electrical port to be interrupted and the optical connection processed after sending “DM” (Disconnected Mode) message to HOST. Any further attempts to communicate on electrical port while the optical port is being used shall be returned with a “DM” code. This is an indication to the host that the meter is temporarily busy.

5 LOGICAL STRUCTURE OF METERS

The meter represents one physical device as mentioned in 4.5 of IEC 62056-62.

The physical device (meter) hosts one logical device as mentioned in 4.5 of IEC 62056-62, which is the Management logical device. This has SAP (Service Access Point) address 1, as mandated in IEC 62056-53. The physical device address (lower HDLC address) shall also be set to a default value of “256” on supply and the actual communication address shall be programmed on installation.

The meter shall support the Logical Name (LN) referencing mechanism as defined in Annex C.1 of IEC 62056-62. Short name referencing as defined in Annex C.2 of IEC 62056-62 is not required to be supported.

The meter shall support three associations in the Management Logical Device

- a) Public Client association (PC)

- b) Meter Reader association (MR)
- c) Utility Settings association (US)

5.1 Mandatory Objects

The following objects as given in Table 2 are mandated by IEC 62056-62.

Table 2 Mandatory Objects
(Clause 5.1)

Sl.No	Object	OBIS Code	Interface Class	Requirements
(1)	(2)	(3)	(4)	(5)
i)	Logical device name	0.0.42.0.0.255	IC-1 (Data)	Value data type will be octet-string with maximum length 16.
ii)	Current Association	0.0.40.0.0.255	IC-15 (Association LN)	This object will refer to the currently connected association object. The meter shall have three association objects, of which the currently connected one shall be accessible via the OBIS 0.0.40.0.0.255

NOTES

1 The Logical Device name shall have a maximum length of 16 characters, and shall have as its first three characters the manufacturer's 3-letter code as specified in 4.6.2 of IEC-62056-62.

2 The three letters Manufacturer ID's are administered by the FLAG Association, in co-operation with the DLMS-UA.

5.2 Association Properties

5.2.1 The PC association shall contain in addition to mandatory objects

- a) The meter's real-time clock
- b) The meter serial number

5.2.2 The MR association shall contain in addition to mandatory objects

- a) Profile objects allowing bulk collection of data defined by the parameter lists in Annexure C, D, E, F and G
- b) Simple objects allowing ad-hoc access to items in the instantaneous parameters list. Ad-hoc access to the profile objects shall also be possible.

5.2.3 The US association shall contain in addition to mandatory objects

- a) All the objects accessible via the MR association;
- b) Simple and compound objects allowing tariffication and configuration of the meter (*see also 9*)

5.2.4 The object list of each association is detailed in Annexure C, D, E, F and G. Mandatory objects do not necessarily appear in these tables. Access rights for each data item are also shown in Annexure C, D, E, F and G. The association properties, object list, and access rights" are identical on ports P1 and P2.

5.2.5 The required associations shall have the properties as given in Table 3.

Table 3 Association Properties
(Clause 5.2.5)

SI No	Feature	Public Client	Meter Reader	Utility Settings
(1)	(2)	(3)	(4)	(5)
i)	SAP Address pair in format (client, server)	(16,1)	(32,1)	(48,1)
ii)	Application Context – Basic security	LN without ciphering	LN without ciphering	LN without ciphering
iii)	Application Context – Advanced security	Not applicable	LN-Ciphered	LN-Ciphered
iv)	Sign on Authentication Mechanism – 7.3.7.2 of IEC-62056-53	Lowest Level	Low Level (LLS)	High Level (HLS)

v)	Services required in conformance block	Get, Get with Block transfer	Get, Get with Block transfer, Selective Access	Get, Set, Action, Get and Set with Block transfer, Selective Access
vi)	OBIS codes	0.0.40.0.1.255	0.0.40.0.2.255	0.0.40.0.3.255

5.3 Descriptive Notes for Logical Structuring

5.3.1 Associations

Each Logical device can organize the data objects into different associations, each having different access rights to the list of objects. Each association defines the SAP address pair of the client and server logical device addresses that participate in the data transaction.

5.3.2 Objects

All meter data is represented by COSEM Interface objects. COSEM interface objects are instances of the COSEM Interface classes.

5.3.3 Attributes & Methods

The actual placeholders of the different data elements of the meter are the attributes of the objects, whereas the methods exposed by the objects allow manipulating the attributes in defined manners.

5.4 Referencing Methods

5.4.1 DLMS/COSEM provides two referencing methods to access the meter data, Logical name referencing and Short Name referencing. Under LN referencing, data is accessed by specifying the Logical name (OBIS code) of the object, the Class ID and the attribute (or method) index. Under SN referencing each attribute and method of each object has its own individual address.

5.4.2 Access rights are specified for each attribute and each method of every data object in the meter. Attributes may have the following access rights

- a) No access
- b) Read access
- c) Write access
- d) Read-Write access

5.4.3 Methods may have the following access rights

- a) No access
- b) Execute access

5.4.4 Access rights are specific to each association. Different associations may have different object lists, or award different access rights to the same set of data objects. Thus the grouping of data into associations gives different views of the same real data.

6 USAGE OF DLMS / COSEM PROVISIONS

6.1 Usage of Interface Classes

6.1.1 This Companion Specification defines the set of Interface Classes to be used for various types of data. The interface class for the identified parameters is specified in Annex C to G.

6.1.2 Either requiring support or offering support for a class shall not imply support for all its attributes. Required attributes are listed under respective Annex as Notes. Not supporting an attribute can be implemented as

- a) Attribute does not appear in the object list
- b) Attribute appears in the object list but with no access rights

6.1.3 Attribute_0 referencing (indicating access to all attributes in one request, as specified by Bit 10 of the conformance block) is not required to be supported in any case.

6.1.4 References to classes may be made in the form of capture-IDs or register-table entries even if the corresponding classes are not supported for direct data access.

6.1.5 References to OBIS codes may be made in the form of capture-IDs, masks, or scripts even if the corresponding objects are not individually accessible. In this case those items will not appear in the Association object.

6.2 Requirements for Interoperability

6.2.1 A client device supporting the parameters, functions, and classes of the Minimum Specification, along with suitable configuration of system-dependent features (such as physical addresses, timeout thresholds, and secret keys), shall be able to retrieve all of the specified data items and perform any of the specified updates without particular knowledge about the server.

6.2.2 Given the knowledge that a certain client or a certain server implements particular additional features defined as in this specification, a server can be built to return data and receive updates from that client, or a client can be built to retrieve data and perform updates upon that server, respectively, without further special knowledge other than system-dependent features.

6.2.3 Interpretation of the data shall be possible by any user with adequate knowledge of electricity metering provided that a complete set of data has been retrieved.

6.3 Country-Specific OBIS Codes

Within this Companion Specification, country-specific variations or additions to quantities such as energy types are managed by the allocation of new codes in the full OBIS format. The country specific OBIS codes introduced in this document are in the format - a.b.94.91.e.f, along with interface class and attributes, where C=94 indicates a country-specific code and D=91 is allocated for India.

7 ASSOCIATION AND DATA SECURITY

As per the provisions of the DLMS/COSEM protocol, Data access control mechanism and Encryption / Authentication mechanism shall be supported. Access control mechanisms shall be used in the Association establishment phase and Encryption / Authentication mechanism shall be used in the Data communication phase.

7.1 Security Profiles

Two Security schemes are defined in this Companion Specification:

7.1.1 *Basic Security*

The basic security profile does not provide for encryption or authentication during data communication stage. The only security provided for is the Sign-on authentication security provided by Low Level and High level security as applicable for the respective Associations.

7.1.2 *Advanced security*

Encryption, authentication, or both can be performed by the application program and transferred using ciphered PDUs. All systems must implement Basic Security. Implementation of Advanced security is discretionary. When implemented it shall be as provided in NIST SP 800-38-D

7.2 Security setup (class_id: 64, version: 0)

The following interface class is defined in addition to those published in the national/international standard (*see also* IEC 62056-62)

Instances of this IC contain the necessary information on the security policy applicable and the security suite in use within a particular AA, between two systems identified by their client system title and server system title respectively. They also contain methods to increase the level of security and to transfer the global keys as given in Table 4.

Table 4 Security Setup
(Clause 6.2)

Security Setup			0...n	Class_id = 64, version = 0			
A)	Attributes		Data Type	Min.	Max.	Def.	Short Name
	(1)		(2)	(3)	(4)	(5)	(6)
(i)	logical name	(static)	octet-string				x
(ii)	security-policy	(static)	enum				x + 0×08
(iii)	security-suite	(static)	enum				x + 0×10
(iv)	client-system-title	(dynamic)	octet-string				x + 0×18
(v)	server-system-title	(static)	octet-string				x + 0×20
B)	Specific Methods		m/o				
(i)	security_activate		o				x + 0×28
(ii)	global_key_transfer		o				x + 0×30

NOTE: Use of this interface class is only required for Advanced Security profile implementations. Implementations of Basic Security profiles shall not contain this Class.

7.3 Security Setup objects

7.3.1 The following object identifiers as given in Table 5 are defined in addition to those published in IEC 62056-62.

Table 5 Object for Security Setup
(Clause 7.3.1)

Security Setup Objects	IC	OBIS code					
		A	B	C	D	E	F
(1)	(2)	(3)	(4)	(5)	(6)	(7)	(8)
Security Setup	64 – Security Setup	0	b	43	0	e	255

7.3.2 Instances of the IC “Security setup” are used to set up the message security features. For each Association object, there is one Security setup object managing security within that AA. Value group E numbers the instances. This companion specification defines 2 values for E corresponding to the 2 associations as given in Table 6.

Table 6 Security Setup Object OBIS Code for Association Levels
(Clause 7.3.2)

SI No	Security Setup Object OBIS Code	Association Description
(1)	(2)	(3)
i)	0.b.43.0.1.255	Meter Reader Association
ii)	0.b.43.0.2.255	Utility Settings Association

NOTE These instances of the Security Setup interface Class are only required for Advanced Security profile implementations. Implementations of Basic Security profile shall not contain these instances.

7.4 LN Association Interface Class

7.4.1 This Companion Specification utilizes version 1 of the Association LN Interface Class (IC 15). The version 1 of IC 15 adds an extra attribute “security_setup_reference” (attribute 9) which will be used to contain the reference to an instance of a Security Setup class (namely one of the two instances defined in Table 6).

7.4.2 The implementation of version 1 of Association LN Interface class is not required for Basic Security profile.

7.4.3 The following Interface Class definition is defined in Table 7 in addition to those published in IEC 62056-62.

7.4.4 COSEM logical devices able to establish AAs within a COSEM context using LN referencing, model the AAs through instances of the “Association LN” IC. A COSEM logical device has one instance of this IC for each AA the device is able to support.

Table 7 LN Association Interface Class
(Clause 7.4.3)

Association LN		0....MaxNbofA	Class_id = 15, version = 1			
		ss	Min.	Max.	Def.	Short Name
SI No	(1)	Data Type	(3)	(4)	(5)	(6)
A)	Attributes					
(i)	logical name (static)	octet-string				x
(ii)	object-list (static)	object_list_type				x + 0×08
(iii)	associated_partners_id	associated_partners_type				x + 0×10
(iv)	application_context_name	application_context_name				x + 0×18
(v)	xdlms_context_info	xdlms_context_type				x + 0×20
(vi)	authentication_mechanism_name	mechanism_name				x + 0×28
(vii)	secret	octet-string				x + 0×30

(viii)	association_status	enum	x + 0×38
(ix)	security_setup_reference (static)	octet-string	x + 0×40
B)	Specific Methods	m/o	
(i)	reply_to_hls_authentication(data)	o	x + 0×60
(ii)	change_hls_secret(data)	o	x + 0×68
(iii)	add_object(data)	o	x + 0×70
(iv)	remove_object(data)	o	x + 0×78

7.5 Descriptive Notes for Data Security

7.5.1 Access Control for Association

The DLMS/COSEM standard provides three different sign-on authentication mechanisms for each association’s access to meter data applied at the time of performing COSEM OPEN operation.

7.5.1.1 Lowest level security

Open access without any authentication at sign-on. This shall be used by the Public Client.

7.5.1.2 Low level security (LLS)

Password based sign-on where the client authenticates itself to the meter using a password. The Utility settings association shall provide access to write the password for all associations that utilize this authentication scheme (Currently only the Meter Reader association object). This is accomplished by providing write access to the “LLS_secret” attribute (attribute number 7) of the Meter Reader association LN object. This write access is provided only through the Utility Settings association.

The MR association object has an OBIS code 0.0.40.0.2.255. The LLS secret of this object shall be changed only through US association..

7.5.1.3 High level security (HLS)

HLS mechanism defines a 4-pass sign-on scheme where the client and server exchange challenges (a random number or code) and then reply to the challenges with a processed response. The processing performed on the challenges is an encryption using a secret “key”. The Utility Settings association shall provide write access to the “secret” attribute of the Utility Settings association. The US association object has an OBIS code 0.0.40.0.3.255. The HLS secret of this object can be changed using method 2 of this object. The encryption mechanism used for processing the challenges shall be AES-128 algorithm as provided in NIST FIPS PUB 197:2001.

7.5.2 Encryption for Data Communication

The confidentiality of data communicated between the meter and the client is handled by the encryption mechanism chosen in the Application Context. Associations utilizing the “Logical Name with ciphering” application context provide encryption/decryption services for data messages. Ciphering may be

- a) Authentication, providing message integrity

- b) Encryption, providing confidentiality
- c) or both

8 EVENT HANDLING

This section adds the definitions for the Event Code object and Event Log object.

8.1 Event Code

8.1.1 An event code object is used to hold the identifier corresponding to most recent event. Data, Register or Extended Register classes can be used to model this object. DLMS allows defining country specific reference table that lists all possible events with corresponding identifiers (*see* Annex G). For the purposes of this Companion Specification the Interface Class used for this object is restricted to IC-1 (Data) as given in Table 8. The value attribute of the object will have a DLMS data type “long unsigned” (16 bit integer) which will contain the event identifier for the last recorded event (identifier taken from the reference tables (*see* Annex G)).

Table 8 Event Code
(Clause 8.1.1)

Event code	IC	OBIS code					
		A	B	C	D	E	F
(1)	(2)	(3)	(4)	(5)	(6)	(7)	(8)
Event code	1 – Data	0	b	96	11	e	255

8.1.2 Value group E allows to classify events into different categories as needed. Currently DLMS allows 10 values (0...9) for value group E, enabling user to define up to 10 event categories.

8.1.3 This Companion Specification defines 7 categories for classification of events and correspondingly 7 Event code objects as given in Table 9.

Table 9 Event Code OBIS Codes
(Clause 8.1.3)

Sl.No.	Event Code object OBIS Code	Event Category Description
(1)	(2)	(3)
i)	0.b.96.11.0.255	Voltage related events

- ii) 0.b.96.11.1.255 Current related events
- iii) 0.b.96.11.2.255 Power failure related events
- iv) 0.b.96.11.3.255 Transaction related events
- v) 0.b.96.11.4.255 Other events
- vi) 0.b.96.11.5.255 Non-rollover events
- vii) 0.b.96.11.6.255 Control events for connect/disconnect

NOTES

1) The 7th Event code object is required only where remote load control by means of connect/disconnect are specified by agreement between the Utility and the manufacturer.

2) Reference to Annex G and the relevant tables may be made for the valid Event Identifier values defined for the above 7 categories by this companion specification.

8.2 Event Log

8.2.1 An event log is a profile generic object provided to store historical values of the event code object for a given category of event. The capture object includes object attribute definitions of associated data. Associated data includes event code and other relevant information such as timestamp, instantaneous electricity related information (such as current/voltage/energy register, contents etc at the time of the event).

8.2.2 For the purposes of this companion Specification, the capture objects will include the entries specified in Annex G.

Table 10 Event Log Profile
(Clause 8.2.1)

Event Logs	IC	OBIS Code					
		A	B	C	D	E	F
(1)	(2)	(3)	(4)	(5)	(6)	(7)	(8)
Event log	7 – Profile Generic	0	b	99	98	e	255

8.2.3 Value group E allows to classify event logs into different categories as needed. Currently DLMS allows 10 values (0...9) for value group E allowing to define up to 10 event log categories as given in Table 11.

8.2.4 This Companion Specification defines 7 categories for classification of event log objects with a one-to-one correspondence with the 7 event code categories defined in 8.1.

8.2.5 Event Log Storage Recommendations

This Companion Specification recommends a total storage of 200 events in the Event logs. The division of the specified storage space across the 7 compartments specified above shall be by the agreement between the utility and the manufacturer.

The event code and event log parameters are accessible through the MR and US associations with read-only access (*see Annex J*).

Table 11 Event Log OBIS Codes
(Clause 8.2.3)

SI No	Event Log Object OBIS Code	Event Category Description
(1)	(2)	(3)
i)	0.b.99.98.0.255	Voltage related events
ii)	0.b.99.98.1.255	Current related events
iii)	0.b.99.98.2.255	Power failure related events
iv)	0.b.99.98.3.255	Transaction related events
v)	0.b.99.98.4.255	Other events
vi)	0.b.99.98.5.255	Non-rollover events
vii)	0.b.99.98.6.255	Control events for connect/disconnect

NOTE The 7th Event log category is required only where remote load control by means of connect/disconnect are specified by agreement between the Utility and the manufacturer

9 TOU METERING

9.1 DLMS/ COSEM provide a number of Interface Classes to deal with TOU metering. These include Activity Calendars (objects that specify the time-switches for tariffs based on a season/week/day profile tree) and Schedules (a simple tabular listing of time-switch scripts associated with a date-time).

9.2 These objects associate a script (stored in a Script Table object, IC-9) with each time-switch. The script usually defines the list of registers that get enabled for that time-switch using a Register Activation object (IC-6) that stores “masks” of registers that can be selectively enabled/disabled.

9.3 For the purpose of this companion specification, the Activity Calendar (IC-20) shall be used as given in Table 12.

Table 12 Activity Calendar OBIS Code
(Clause 9.3)

Activity Calendar	IC	OBIS Code					
		A	B	C	D	E	F
(1)	(2)	(3)	(4)	(5)	(6)	(7)	(8)
Activity Calendar	20 – Activity Calendar	0	b	13	0	0	255

9.4 An instance of a Script Table class, the Tariffication Script Table object will be used to store the scripts related to each time-switch in the Schedule as given in Table 13.

Table 16 Tariff Script Table OBIS Code
(Clause 9.4)

Script Table	IC	OBIS Code					
		A	B	C	D	E	F
(1)	(2)	(3)	(4)	(5)	(6)	(7)	(8)
Tariffication Script Table	9 – Script Table	0	b	10	0	100	255

9.5 This Companion specification utilizes a simple mechanism for associating TOU/TOD scripts with Tariffs, as described below. Use of the Register Activation object is not required.

9.6 Under this mechanism, script identifiers in the Tariffication Script Table are inherently associated with Tariffs, as defined below.

9.7 Script identifiers from 1 to 16 are associated with the Activation of Tariff Rate Registers 1 to 16. Implementations that do not require 16 different tariff rates shall use identifiers from 1 to the required number. For example if 8 tariffs are defined, script identifiers 1 to 8 shall be used, where scripts 9 to 16 are reserved for future use. Scripts identifiers 17 to 32 are associated with Maximum Demand tariffs 1 to 16. Implementations that do not require 16 different tariff rates shall use identifiers from 1 to the required number.

9.8 The Activity Calendar shall be used to associate activation times to different Tariff rates simply by using the appropriate script identifiers. All scripts shall point to a dummy OBIS code and attribute index which has no associated meaning.

9.9 To ensure coordination of the updates to various attributes, activity calendar shall be updated by writing to the passive-calendar attributes. The end of the update process is indicated by update of the Activation Date attribute with an appropriate value, causing all changes to become effective simultaneously.

9.10 Use of the Special Days table is not considered presently in this Companion Specification.

10 BILLING PERIODS

10.1 Billing period resets are driven by an instance of the Single Action Schedule class in conjunction with a Script Table. The Data of the Billing Period is stored in a Profile Generic object as given in Table 14. Each entry in the profile buffer captures the billing period values for a specific Billing Period.

Table 14 Billing Period OBIS Code
(Clause 10.1)

Profile Generic	IC	OBIS Code					
		A	B	C	D	E	F
(1)	(2)	(3)	(4)	(5)	(6)	(7)	(8)
Data of Billing Period Profile	7 – Profile Generic	1	b	98	1	0	255

10.2 This Companion Specification specifies the Single Action Schedule object to drive the end of billing period resets as given in Table 15. The object will contain the time-date entries at which billing period resets are scheduled.

Table 15 Single Action Schedule OBIS Code
(Clause 10.2)

Single Action Schedule	IC	OBIS Code					
		A	B	C	D	E	F
(1)	(2)	(3)	(4)	(5)	(6)	(7)	(8)
MDI Reset / End of Billing Period	22 – Single Action Schedule	0	b	15	0	0	255

10.3 Each time-date entry in the “execution_time” array will be associated with a link to a single Script in the MDI Reset/End of Billing Period Script Table. The Script table object as given in Table 16 will be programmed with scripts to handle the Billing period resets.

Table 16 Billing Script Table OBIS Code
(Clause 10.3)

Script Table	IC	OBIS Code					
		A	B	C	D	E	F
(1)	(2)	(3)	(4)	(5)	(6)	(7)	(8)
MDI Reset / End of Billing Period Script Table	9 – Script Table	0	b	10	0	1	255

10.4 The script table will contain a single script that specifies the “capture” method invocation for the corresponding Data of Billing Period profile (1.0.98.1.0.255). Therefore a Single Action Schedule entry will trigger a call to the Script table to execute the capture method at a specific time (viz. the end of the billing period) which will cause a billing period entry to be made in the profile for the current period and trigger the start of a new billing period. Other actions internal to the meter may also be triggered by the end of each billing period, but are not required to be expressed as scripts here.

11 HISTORIC DATA

11.1 Historic data can be accessed by two mechanisms in DLMS-COSEM. One mechanism provides access to past values of specific quantities by using a VZ (billing period number) related value for F in the OBIS code of the original quantity. The other mechanism is profile generic objects, where individual billing data set is one entry. Profile generic object method is supported in this Indian companion for accessing historical data.

11.2 Billing Period Counter

11.2.1 The meter will contain an instance of a Billing period counter object as given in Table 17.

Table 17 Billing Period Counter OBIS Code
(Clause 11.2.1)

Billing Period Counter	IC	OBIS Code					
		A	B	C	D	E	F
(1)	(2)	(3)	(4)	(5)	(6)	(7)	(8)
Billing Period Counter	1 – Data	0	b	0	1	0	255

11.2.2 The value attribute of the object will have a DLMS data type “unsigned 32 bit” and cumulative value since installation. The meter will contain an instance of a Data object that provides the number of available billing periods in the meter as given in Table 18.

Table 18 Available Billing Periods OBIS Code
(Clause 11.2.2)

Number of Billing Periods	IC	OBIS Code					
		A	B	C	D	E	F
(1)	(2)	(3)	(4)	(5)	(6)	(7)	(8)
Available Billing periods	1 – Data	0	b	0	1	1	255

11.2.3 The above can be read by the client to identify how many previous billing period's data is available in the meter. The value attribute of the above object will have a DLMS data type "unsigned" (8-bit character)

11.3 Profiles

11.3.1 Historic data like Load profiles etc. are supported in IEC 62056 by the Profile generic Interface Class (IC 7). This object supports capture of other meter object attributes at specific intervals or on demand. The captured data is stored in the buffer attribute (Attribute 2) of the Profile generic class. This class also supports Selective access to filter the buffer data in response to GET requests. There are two mechanisms for selective access viz. Selective access by Entry and Selective Access by Range.

11.3.2 This Companion Specification requires that the Selective Access by Range shall be supported for Block Load profile and Daily Load profile. This companion specification requires support for Selective Access by Entry for Billing data profile and Event log profiles.

11.3.3 In case of Selective access by Range, this companion specification imposes that the restricting object is to be an instance of the Clock interface class (IC-8) and the date-time attribute of the object is captured in the buffer.

11.3.4 Selective access by entry and range supports filtering the profile buffer by rows as well as by columns. However this Companion Specification doesn't require support for filtering by columns.

11.3.5 Any configuration change in profile capture object will be treated as 5.6 of IEC 62056-62 (*see* also Annex K)

12 COMMUNICATION PROFILES

IS/IEC 52056 adopts the Collapsed Architecture subset of the Open Systems Interconnect Reference Model. Figure 2 below illustrates the system used. This Companion Specification requires that the three-layer serial Connection-Orientated (CO) profile shall at least be supported.

The 3-layer serial CO profile consists of COSEM, Logical Link Control (LLC), and High-Level Distribution Line Control (HDLC) on a serial physical channel. This profile may be extended by using modems to handle different carriers such as PSTN, GSM, or GPRS, Radio, Zigbee etc. by tunneling HDLC frames over these media.

The addition of dial-up modem connections as described in IEC 62056-42 is required only where modem is fitted internal to the meter.

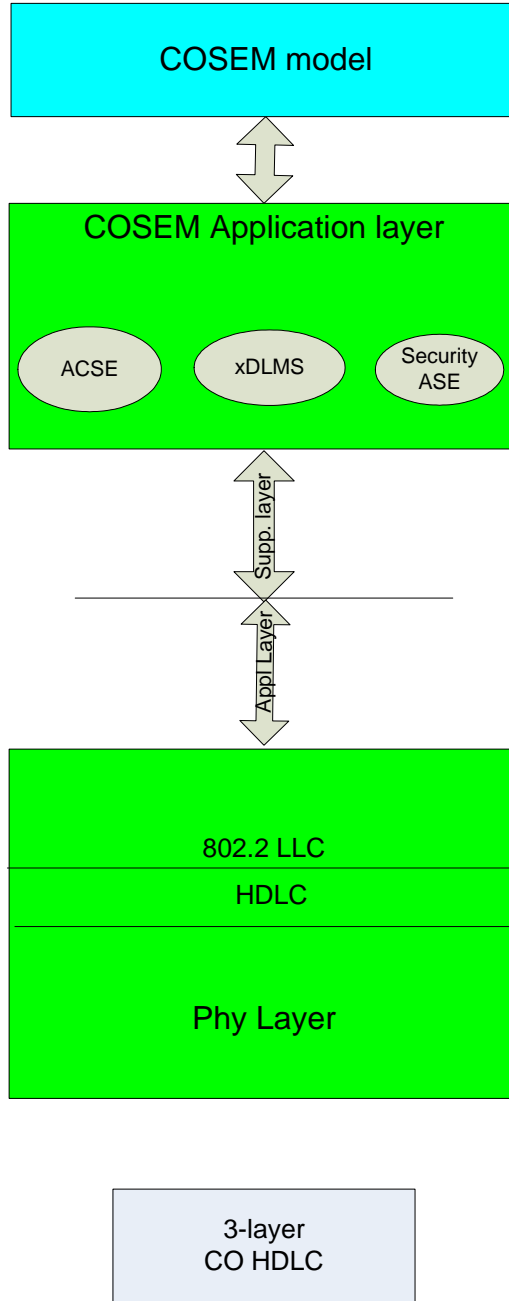

Fig. 2 COMMUNICATION PROFILE OPTIONS

13 COMMUNICATION SETUP OBJECTS

This Companion Specification requires the communication setup objects as given in Table 19 to be supported in the meter implementation. This document also recommends that a specific baud rate may be fixed between the utility and the manufacturer for each project. The suggested default baud rate is given in 4.2.

Table 19 Communication Set Up Object
(Clause 13)

Communication Setup and Related Objects for Serial Communication	IC	OBIS Code					
		A	B	C	D	E	F
(1)	(2)	(3)	(4)	(5)	(6)	(7)	(8)
IEC HDLC Setup	23 - IEC HDLC Setup	0	b	22	0	0	255

14 CONNECT/DISCONNECT CONTROL

In implementations that require remote Connect/Disconnect control, effected by operation of an output pulse from the meter, this companion specification requires support for the Disconnect class object as given in Table 20.

Table 20 Disconnect Control Object
(Clause 14)

Disconnect	IC	OBIS Code					
		A	B	C	D	E	F
(1)	(2)	(3)	(4)	(5)	(6)	(7)	(8)
Disconnect Control	70 – Disconnect Control	0	b	96	3	10	255

ANNEX A
(Foreword)

INTRODUCTION TO STANDARDIZED METER PARAMETERS LIST

A-1 CLASSIFICATION OF PARAMETERS

The Metering Parameters have been identified and classified as follows:

- a) Instantaneous Parameters
- b) Block Profile / Load Survey Parameters.
- c) Daily Profile Parameters.
- d) Parameters for accounting / billing.
- e) General Purpose quantities
 - i. Name Plate Details.
 - ii. Programmable parameters
- f) Event Conditions.

The measurement and computation of each of these parameters and events shall be based on standard methods or based on utilities prudent practices or as directed by respective Regulatory Commission.

For each of the identified parameter, the OBIS code, Interface Class and the Attributes are given in the various tables in corresponding Annexure. The OBIS codes listed are applicable for LN referencing and is mandatory to adhere to by the SERVERS and CLIENTS.

A-2 INSTANTANEOUS PARAMETERS

The Instantaneous parameters shall be continuously updated by the meter hardware / software as per internal sampling and computation time. The energy values in the table shall be cumulative readings from the date of manufacturing or installation of meter as the case may be. These shall be continuously updated and last updated value shall be available for downloading as and when required. Each of the parameters shall be readable at any instant by the HOST from remote or by HHU at site. The snap shot of all the instantaneous values of all parameters shall be readable by the HOST computer.

A-3 PROFILE GENERIC OR LOAD SURVEY PARAMETERS (CAPTURE TIME BLOCK 15 OR 30 MINUTES)

This is an array of parameters identified for capturing and storing at specified time intervals or capture times. The capture times shall be either 15 or 30 minutes. The capture times shall be programmable by the utilities. The tables lists the parameters whose profile (survey) is to be captured and stored in the meter as per set capture time period. The profiles shall be readable at any time by the HOST from remote or by HHU (MRI) at site for any specified range and time.

In the case of Category B meters the capture time shall be of 15 minutes duration.

The data stored in the array shall be the average value for the captured time block and stored at the end of that block, except for energy values. The energy entries are the consumption during respective capture time block and posted at the end of that block. The array of data shall be retained inside the meter memory for the last 22 days for a capture period of 15 minutes or for the last 45 days for a capture period of 30 minutes. It is assumed that the number of load survey parameters is 5 which can be selected from the respective tables by the utilities. The storage days can be expanded by choosing less number of parameters.

The block load profiles shall not store or return values (typically zero values) for conditions where the meter is powered down for a full day, where a full day is defined as the 24 hour period from midnight 00 Hrs to the next midnight 00 Hrs. Under such conditions the block load profile for the entire 24 Hour period shall not be stored nor padded with zero entries. However if the meter is powered up even for a small amount of time (sufficient for it to boot up and record the Power up event) during the 24 Hour period, it shall store and return the Block load profile for the entire 24 hour duration.

A-4 PARAMETERS FOR ACCOUNTING / BILLING PURPOSE

These are parameters identified for accounting / billing purposes. These shall be generated by the meter for each billing cycle and stored in the memory. The set of data for last 6 (six) cycles shall be stored in the memory. At the end of each cycle corresponding set of data shall be readable by the HOST from remote or by HHU at site.

A-5 GENERAL PURPOSE QUANTITIES

A-5.1 Name Plate Details

These parameters are electrical and non-electrical quantities and are static in nature, grouped as “Name Plate Details”, containing pertinent information about the supplied meter. The parameters identified and grouped as “Name Plate Details” under this classification are applicable for all categories of meters(see Annex F).

A-5.2 Programmable Parameters

These parameters are non electrical quantities. The parameters identified and grouped as “Programmable Parameters” shall be programmable by the Utility engineers. For the purpose of setting / altering the values of these parameters, the security and access rights in line with the methodology described in protocol, shall be mutually agreed between utility and manufacturer. The parameters shall be programmable by HOST from remote and HHU at site. These are applicable for all categories of meters(see Annex F).

A-6 EVENT CONDITIONS

A-6.1 Any abnormal or a tamper condition is defined as an Event. The meters shall identify and log both occurrence and restoration of such events. The meters shall also

capture some of the parameters at the instance of above said log. This specification has identified the events to be logged and the parameters to be captured for each of those events(see Annex G).

A-6.2 This Companion Specification has further classified those events in sub groups for easy handling. The sub groups are

- a. Voltage related events
- b. Current related events
- c. Power Failure related events
- d. Transactional events
- e. Other events
- f. Non rollover events
- g. Control events

A-6.3 The number of events stored in each compartment shall be decided by agreement between the Utility and Manufacturers. However the total number of events shall be 200.

A-6.4 The event conditions identified are listed in Table 37 to Table 43 of Annex G covering all the subgroups. For each type of event condition the parameters to be captured are listed in Table 44 of Annex G. The required capture parameters for selected event condition shall be chosen by the utility as per its practices and directives.

A-6.5 The types of events to be recorded may be selected by the Utility out of the list provided in tables Table 37 to Table 43 of Annex G as per Utility need and practice. The parameters for which Snapshot is to be recorded at time of tamper / event can also be selected out of list of parameters provided in “Capture Parameters” in Table 44 of Annex G.

A-6.6 The servers shall be capable of providing the entire list of parameters listed in the respective Annexure. However the utility as per its practices and directives may choose required parameters from the full list. Sequence of parameters in buffer shall be derived from capture object. The OBIS code for such selected parameters however shall remain as assigned.

ANNEX B

(Clause 1.3)

INTRODUCTION TO METERING PARAMETERS WITH DATA IDENTIFIERS

B-1 Three categories of electricity meters have been selected for compiling comprehensive lists of metering parameters with their data identifiers as required for data networks in India for COSEM procedures and services. The relevant reference documents are listed in 2.

B-2 The meters complying with this specification shall be considered as servers in a data network. The data collecting devices at the head end or HHU shall function as client and seek required services from these servers. Table 21 lists the server categories with metering nomenclatures and Annex references.

Table 21 Categories of Meters

(Clause B-2)

SI No	Server Category	Metering Nomenclature / Purpose	Annex
(1)	(2)	(3)	(4)
i)	A	Energy Accounting and Audit Metering	C, F,G
ii)	B	Boundary / Bank / Ring / ABT Metering	D, F,G
iii)	C	HV (PT / CT) and LV (CT) consumer Metering	E, F,G

B-1.1 Category A Meter

This meter is identified for use at sub-station feeders and Distribution Transformer Centers. The parameters listed for this category is for “Energy Accounting and Audit” purposes (*see* also Annex C).

B-1.2 Category B Meter

This meter is identified for use at Meter Banks and Network boundaries. The parameters listed for this category is for import / export of energy. This meter is also suitable for Availability Based Tariff (ABT) regime (*see* also Annex D).

B-1.3 Category C Meter

This meter is identified for use at HV (PT and CT operated) and LV (CT operated) consumers. The parameters listed for this category is for consumers who draw energy from the grid. For consumers who also supply energy to grid, the category B Meter is recommended (*see* also Annex E).

ANNEX C

(Clause B-1.1, Table 21)

PARAMETER LIST FOR ‘CATEGORY A’ METERS

C-1 The parameters listed here are for Energy Accounting & Audit purposes. These meters are identified for Feeder metering and DTC metering where the power flow is unidirectional. In circumstances where bidirectional power flow is to be measured then Category B Meters shall be deployed.

C-2 The parameters identified are grouped under Instantaneous (Table 22) and Block load profile (Table 23). The tables include the name of the parameter, the OBIS code and Interface class.

C-3 Association Access Rights are as follows:

- a) Public Client - Read Only for Clock and no access for other objects.
- b) Meter Reader – Read Only for all objects.
- c) Utility Setting – Read & Write for Clock and Read Only for others.

C-4 INSTANTANEOUS PARAMETERS

Each of the parameters is a separate entity. The OBIS code for each parameter is identified as per DLMS /COSEM protocol.

C-4.1 Snap Shot Of Instantaneous Parameters

The parameters of Table 22 shall be captured as a profile generic using the country specific OBIS code 1.0.94.91.0.255; the attribute 2 of each of the capture objects shall be copied into the profile at the instant of a request from the Host.

Table 22 Instantaneous Parameters for Class A Meters

(Clause C-2 & C-4.1)

SI No	Parameter	OBIS Code A.B.C.D.E.F	Interface Class No
(1)	(2)	(3)	(4)
i)	Real Time Clock – Date and Time	0.0.1.0.0.255	8
ii)	Current - IR	1.0.31.7.0.255	3

iii)	Current – IY	1.0.51.7.0.255	3
iv)	Current – IB	1.0.71.7.0.255	3
v)	Voltage – VRN	1.0.32.7.0.255	3
vi)	Voltage – VYN	1.0.52.7.0.255	3
vii)	Voltage – VBN	1.0.72.7.0.255	3
viii)	Voltage – VRY	1.0.32.7.0.255	3
ix)	Voltage – VBY	1.0.52.7.0.255	3
x)	Signed Power Factor –R phase	1.0.33.7.0.255	3
xi)	Signed Power Factor - Y phase	1.0.53.7.0.255	3
xii)	Signed Power Factor - B phase	1.0.73.7.0.255	3
xiii)	Three Phase Power Factor – PF	1.0.13.7.0.255	3
xiv)	Frequency	1.0.14.7.0.255	3
xv)	Apparent Power – KVA	1.0.9.7.0.255	3
xvi)	Signed Active Power – kW (+ Forward; - Reverse)	1.0.1.7.0.255	3
xvii)	Signed Reactive Power – kvar (+ Lag; - Lead)	1.0.3.7.0.255	3
xviii)	Cumulative Energy – kWh	1.0.1.8.0.255	3
xix)	Cumulative Energy – kvarh – Lag	1.0.5.8.0.255	3
xx)	Cumulative Energy – kvarh – Lead	1.0.8.8.0.255	3
xxi)	Cumulative Energy – kVAh	1.0.9.8.0.255	3
xxii)	Number of Power-Failures.	0.0.96.7.0.255	1
xxiii)	Cumulative Power-Failure Duration	0.0.94.91.8.255	3
xxiv)	Cumulative Tamper Count	0.0.94.91.0.255	1

xxv)	Cumulative Billing Count	0.0.0.1.0.255	1
xxvi)	Cumulative Programming Count	0.0.96.2.0.255	1
xxvii)	Billing Date	0.0.0.1.2.255	3
xxviii)	Maximum Demand – kW	1.0.1.6.0.255	4
xxix)	Maximum Demand – kVA	1.0.9.6.0.255	4

NOTES

- 1) The items at SI No v), vi), and vii) are for 3Φ / 4W system of measurement with NEUTRAL as reference point.
- 2) The items at SI No viii) and ix) are for 3 Φ / 3W system of measurement with Y-PHASE as reference point.
- 3) Signed Power factor: (+) indicates lag and (-) indicates lead.
- 4) The parameters at SI No xviii) to xxvi) hold cumulative values at that instant from the date of manufacturing or installation of meter as the case may be.
- 5) The above list is identified for the purpose of communication to HOST or HHU.
- 6) The utilities may choose, based on needs, additional parameters for display purpose ONLY.
- 7) Item number at SI No xxv) refers to the Billing Period Counter.

C-4.2 Scaler Profile

This profile is meant for capturing the Scaler-unit of each of the parameter listed in Table 22. This is modeled as profile generic (IC=7) and is assigned the country specific OBIS code 1.0.94.91.3.255. The capture objects for this profile shall include the scaler-unit attributes of the Instantaneous parameters listed above. Instantaneous parameters that do not have a scaler-unit (like IC 1) shall not be included in the capture objects list. The profile buffer shall have only one entry. This profile is not required to be updated periodically

C-5 BLOCK LOAD PROFILE PARAMETERS

This is an array of load survey data captured as a profile generic. The OBIS code is 1.0.99.1.0.255, with Interface class as 7. The capture objects of this block load profile are as per Table 23 and the captured attribute shall be attribute 2 of each interface class. The capture object values will be copied into buffer of this array automatically as per capture period which shall be set through OBIS code 1.0.0.8.4.255 of recording interval 1.

Association Access Rights are as follows:

- a) Public Client - No access for all objects.
- b) Meter Reader – Read only for all objects.
- c) Utility Setting – Read only for all objects.

Table 23 Block Load Survey Parameters for Class A Meters
(Clause C-2 & C-5)

SI No	Parameter	OBIS Code A.B.C.D.E.F	Interface Class No / Attribute
(1)	(2)	(3)	(4)
i)	Real Time Clock – Date and Time	0.0.1.0.0.255	8 / 2
ii)	Current - IR	1.0.31.27.0.255	3 / 2
iii)	Current – IY	1.0.51.27.0.255	3 / 2
iv)	Current – IB	1.0.71.27.0.255	3 / 2
v)	Voltage – VRN	1.0.32.27.0.255	3 / 2
vi)	Voltage – VYN	1.0.52.27.0.255	3 / 2
vii)	Voltage – VBN	1.0.72.27.0.255	3 / 2
viii)	Voltage – VRY	1.0.32.27.0.255	3 / 2
ix)	Voltage – VBY	1.0.52.27.0.255	3 / 2
x)	Block Energy – kWh	1.0.1.29.0.255	3 / 2
xi)	Block Energy – kvarh – lag	1.0.5.29.0.255	3 / 2
xii)	Block Energy – kvarh – lead	1.0.8.29.0.255	3 / 2
xiii)	Block Energy – kVAh	1.0.9.29.0.255	3 / 2

NOTES

- 1) The items at SI No v), vi), and vii) are for 3Φ / 4W system of measurement with NEUTRAL as reference point.
- 2) The items at SI No viii) and ix) are for 3 Φ / 3W system of measurement with Y-PHASE as reference point.
- 3) The parameters at SI No ii) to ix) are the average values during the block period time and stored at the end of that time block.
- 4) The parameters at SI No x) to xiii) are the actual energy consumption during that time block.
- 5) Capture objects for 3 Φ / 4W are items SI No i) to vii) and x) to xiii)
- 6) Capture objects for 3 Φ / 3W are items SI No i) to iv) and viii) to xiii)
- 7) Support for Selective access shall be as defined in 11.3

C-6 PARAMETERS FOR ACCOUNTING / BILLING

The list of parameters in Table 22 and Table 23 shall be used for computing the daily accounting data at the HOST.

C-6.1 Scaler Profile

This profile is meant for capturing the Scaler-unit of each of the parameter listed in Table 23. This is modeled as profile generic (IC=7) and is assigned the country specific OBIS code 1.0.94.91.4.255. The capture objects for this profile shall include the scaler-unit attributes of the parameters listed above. The profile buffer shall have only one entry. This profile is not required to be updated periodically

ANNEX D

(Clause B-1.2, Table 21)

PARAMETER LIST FOR ‘CATEGORY B’ METERS

D-1 The parameters listed here are for Boundary / Bank / Ring Fencing / ABT Metering. The meter records parameters under import and or export conditions.

D-2 The parameters identified for this are grouped under Instantaneous (Table 24), Block load profile (Table 25) and Daily Load profile (Table 26). The tables include the name of the parameter, the OBIS code and Interface class.

D-3 INSTANTANEOUS PARAMETERS

Each of the parameters is a separate entity. The OBIS code for each parameter is identified as per DLMS /COSEM protocol.

Association Access Rights are as follows:

- a) Public Client - Read Only for Clock and no access for other objects.
- b) Meter Reader – Read only for all objects.
- c) Utility Setting – Read & Write for Clock and Read Only for others.

D-3.1 Snap Shot of Instantaneous Parameters

The parameters of Table 24 shall be captured as a profile generic using the country specific OBIS code 1.0.94.91.0.255. The attribute 2 of each of the capture objects shall be copied into the profile at the instant of a request from the Host.

Table 24 Instantaneous Parameters for Class B Meters
(Clause D-2 & D-3.1)

SI No	Parameter	OBIS Code A.B.C.D.E.F	Interface Class No
(1)	(2)	(3)	(4)
i)	Real Time Clock – Date and Time	0.0.1.0.0.255	8
ii)	Current - IR	1.0.31.7.0.255	3
iii)	Current – IY	1.0.51.7.0.255	3
iv)	Current – IB	1.0.71.7.0.255	3
v)	Voltage – VRN	1.0.32.7.0.255	3

vi)	Voltage – VYN	1.0.52.7.0.255	3
vii)	Voltage – VBN	1.0.72.7.0.255	3
viii)	Voltage – VRY	1.0.32.7.0.255	3
ix)	Voltage – VBY	1.0.52.7.0.255	3
x)	Signed Power Factor - R phase	1.0.33.7.0.255	3
xi)	Signed Power Factor - Y phase	1.0.53.7.0.255	3
xii)	Signed Power Factor - B phase	1.0.73.7.0.255	3
xiii)	Three Phase Power Factor – PF	1.0.13.7.0.255	3
xiv)	Frequency	1.0.14.7.0.255	3
xv)	Apparent Power – KVA	1.0.9.7.0.255	3
xvi)	Signed Active Power – kW (+ import: - export)	1.0.1.7.0.255	3
xvii)	Signed Reactive Power – kvar (+ Lag; - Lead)	1.0.3.7.0.255	3
xviii)	Cumulative Energy – kWh (Import)	1.0.1.8.0.255	3
xix)	Cumulative Energy – kWh (Export)	1.0.2.8.0.255	3
xx)	Cumulative Energy – kVAh(Import)	1.0.9.8.0.255	3
xxi)	Cumulative Energy – kVAh(Export)	1.0.10.8.0.255	3
xxii)	Number of Power-Failures.	0.0.96.7.0.255	1
xxiii)	Cumulative Power-Failure Duration	0.0.94.91.8.255	3
xxiv)	Cumulative Tamper Count	0.0.94.91.0.255	1
xxv)	Cumulative Billing Count	0.0.0.1.0.255	1
xxvi)	Cumulative programming Count	0.0.96.2.0.255	1
xxvii)	Billing Date	0.0.0.1.2.255	3

NOTES

- 1) The items at SI No v), vi) and vii) are for 3Φ / 4W system of measurement with NEUTRAL as reference point.
- 2) The items at SI No viii), ix) are for 3 Φ / 3W system of measurement with Y-PHASE as reference point.
- 3) Signed Power factor: (+) indicates lag and (-) indicates lead.
- 4) The parameters at SI No xviii) to xxvi) hold cumulative values at that instant from the date of manufacturing or installation of meter as the case may be.
- 5) The above list is identified for the purpose of communication to HOST or HHU.
- 6) The utilities may choose, based on needs, additional parameters for display purpose ONLY.
- 7) Item number at SI No xxv) refers to the Billing Period Counter

D-3.2 Scaler Profile

This profile is meant for capturing the Scaler-unit of each of the parameter listed in Table 24. This is modeled as profile generic (IC=7) and is assigned the country specific OBIS code 1.0.94.91.3.255. The capture objects for this profile shall include the scaler-unit attributes of the Instantaneous parameters listed above. Instantaneous parameters that do not have a scaler-unit (like IC 1) shall not be included in the capture objects list. The profile buffer shall have only one entry. This profile is not required to be updated periodically.

D-4 BLOCK LOAD PROFILE PARAMETERS

This is an array of load survey data captured as a profile generic. The OBIS code is 1.0.99.1.0.255, with Interface class as 7. The capture objects of this block load profile are as per Table 25 and the captured object shall be attribute 2 of each interface class. The capture object values will be copied into a buffer of this array automatically as per capture period which shall be set through OBIS code 1.0.0.8.4.255 of recording interval 1.

Association Access Rights are as follows:

- a) Public Client – No access for all objects
- b) Meter Reader – Read only for all objects.
- c) Utility Setting – Read only for all objects.

Table 25 Block Load Survey Parameters for Class B Meters
(Clause D-2 & D-4)

SI No	Parameter	OBIS Code A.B.C.D.E.F	Interface Class No / Attribute
(1)	(2)	(3)	(4)
i)	Real Time Clock – Date and Time	0.0.1.0.0.255	8 / 2
ii)	Frequency	1.0.14.27.0.255	3 / 2

iii)	Voltage – VRN	1.0.32.27.0.255	3 / 2
iv)	Voltage – VYN	1.0.52.27.0.255	3 / 2
v)	Voltage – VBN	1.0.72.27.0.255	3 / 2
vi)	Energy – Active Import	1.0.1.29.0.255	3 / 2
vii)	Energy – Net Active Energy	1.0.16.29.0.255	3 / 2
viii)	Energy – Active Export	1.0.2.29.0.255	3 / 2
ix)	Energy – kvarh – Quadrant I	1.0.5.29.0.255	3 / 2
x)	Energy – kvarh – Quadrant II	1.0.6.29.0.255	3 / 2
xi)	Energy – kvarh – Quadrant III	1.0.7.29.0.255	3 / 2
xii)	Energy – kvarh – Quadrant IV	1.0.8.29.0.255	3 / 2

NOTES

- 1) The parameters listed in this table are for load survey purpose and are logged as per the block period time.
- 2) The Block period time for Interface meters is fixed at 15 min for which the data storage will be for 22 days.
- 3) The parameters at SI No iii) to vi) are the average values of 15 min block and stored at the end of that time block.
- 4) The parameters at SI No vii) to xii) are the actual energy consumption during the 15 min time block.
- 5) Item at SI No ii) is an ABT parameter for absolute average value.
- 6) Item at SI No vii) is an ABT parameter for Net energy in the current 15 min block.
- 7) Support for Selective access shall be as defined in Section 11.3.

D-4.1 Scaler Profile

This profile is meant for capturing the Scaler-unit of each of the parameter listed in Table 25. This is modeled as profile generic (IC=7) and is assigned the country specific OBIS code 1.0.94.91.4.255. The capture objects for this profile shall include the scaler-unit attributes of the parameters listed above. The profile buffer shall have only one entry. This profile is not required to be updated periodically.

D-5 DAILY LOAD PROFILE PARAMETERS

This is an array of load survey data captured as a profile generic at the end of 24 hours. The OBIS code is 1.0.99.2.0.255, with Interface class as 7. The capture objects of this daily load profile are as per Table 26 and the captured attribute shall be attributing 2 of each interface class. The capture object values will be copied into a buffer of this array automatically as per capture period which shall be set through OBIS code 1.0.0.8.5.255 of recording interval 2. The capture period attribute shall be statically fixed as 24 hours.

Association Access Rights are as follows:

- a) Public Client – No access for all objects
- b) Meter Reader – Read only for all objects.
- c) Utility Setting – Read only for all objects.

Table 26 Daily Load Profile Parameters for Class B Meters
(Clause D-2 & D-5)

SI No	Parameter	OBIS Code	Interface Class No / Attribute
(1)	(2)	A.B.C.D.E.F (3)	(4)
i)	Real Time Clock – Date and Time	0.0.1.0.0.255	8 / 2
ii)	Cumulative Energy – kWh – Import	1.0.1.8.0.255	3 / 2
iii)	Cumulative Energy – kWh – Export	1.0.2.8.0.255	3 / 2
iv)	Cumulative Energy – kVAh while kW Import	1.0.9.8.0.255	3 / 2
v)	Cumulative Energy – kVAh while kW Export	1.0.10.8.0.255	3 / 2
vi)	Reactive Energy High (V > 103%)	1.0.94.91.1.255	3 / 2
vii)	Reactive Energy Low (V < 97%)	1.0.94.91.2.255	3 / 2
viii)	Cumulative Energy – kvarh – Quadrant 1	1.0.5.8.0.255	3 / 2
ix)	Cumulative Energy – kvarh – Quadrant 2	1.0.6.8.0.255	3 / 2
x)	Cumulative Energy – kvarh – Quadrant 3	1.0.7.8.0.255	3 / 2
xi)	Cumulative Energy – kvarh – Quadrant 4	1.0.8.8.0.255	3 / 2

NOTES

- 1) The parameters listed in this table are meant for billing purpose and shall be logged at midnight (00 Hrs).
- 2) The storage time for these parameters is 22 days.
- 3) The parameters at SI No ii) to xi) are cumulative values at that instant from the date of manufacturing or installation of meter as the case may be.
- 4) Item at SI No vi) is an ABT parameter.
- 5) Item at SI No vii) is an ABT parameter.
- 6) Support for Selective access shall be as defined in Section 11.3

D-5.1 Scaler Profile

This profile is meant for capturing the Scaler-unit of each of the parameter listed in Table 26. This is modeled as profile generic (IC=7) and is assigned the country specific OBIS code 1.0.94.91.5.255. The capture objects for this profile shall include the scaler-unit attributes of the parameters listed above. The profile buffer shall have only one entry. This profile is not required to be updated periodically.

ANNEX E
(Clause B-1.3, Table 21)

PARAMETER LIST FOR ‘CATEGORY C’ METERS

E-1 The parameters listed here are for HT (PT / CT) and LT (CT) consumer metering. This meter records energy in import mode. These meters shall be capable of recording Import of energy. For customers who import energy and also export energy, use of category B meters is recommended.

E-2 The parameters identified for this are grouped under Instantaneous (Table27), Block load profile (Table 28), and Billing (Table 29). The tables include the name of the parameter, the OBIS code and Interface class.

E-3 INSTANTANEOUS PARAMETERS

Each of the parameters is a separate entity. The OBIS code for each parameter is identified as per DLMS /COSEM protocol.

Association Access Rights are as follows:

- a) Public Client - Read only for Clock and no access for other objects.
- b) Meter Reader – Read only for all objects.
- c) Utility Setting – Read & Write for Clock and Read Only for others.

E-3.1 Snap Shot of Instantaneous Parameters

The parameters of Table 27 shall be captured as a profile generic using the country specific OBIS code 1.0.94.91.0.255. The attribute 2 of each of the capture objects shall be copied into the profile at the instant of a request from the Host.

Table 27 Instantaneous Parameters for Class C Meters
(Clause E-2 & E-3.1)

SI No	Parameter	OBIS Code A.B.C.D.E.F	Interface Class No
(1)	(2)	(3)	(4)
i)	Real Time Clock – Date and Time	0.0.1.0.0.255	8
ii)	Current - IR	1.0.31.7.0.255	3
iii)	Current – IY	1.0.51.7.0.255	3
iv)	Current – IB	1.0.71.7.0.255	3

v)	Voltage – VRN	1.0.32.7.0.255	3
vi)	Voltage – VYN	1.0.52.7.0.255	3
vii)	Voltage – VBN	1.0.72.7.0.255	3
viii)	Voltage – VRY	1.0.32.7.0.255	3
ix)	Voltage – VBY	1.0.52.7.0.255	3
x)	Signed Power Factor –R phase	1.0.33.7.0.255	3
xi)	Signed Power Factor - Y phase	1.0.53.7.0.255	3
xii)	Signed Power Factor - B phase	1.0.73.7.0.255	3
xiii)	Three Phase Power Factor – PF	1.0.13.7.0.255	3
xiv)	Frequency	1.0.14.7.0.255	3
xv)	Apparent Power – KVA	1.0.9.7.0.255	3
xvi)	Signed Active Power – kW (+ Forward; - Reverse)	1.0.1.7.0.255	3
xvii)	Signed Reactive Power – kvar (+ Lag; - Lead)	1.0.3.7.0.255	3
xviii)	Number of Power-Failures	0.0.96.7.0.255	1
xix)	Cumulative Power-Failure Duration	0.0.94.91.8.255	3
xx)	Cumulative Tamper Count	0.0.94.91.0.255	1
xxi)	Cumulative Billing Count	0.0.0.1.0.255	1
xxii)	Cumulative Programming Count	0.0.96.2.0.255	1
xxiii)	Billing Date	0.0.0.1.2.255	3
xxiv)	Cumulative Energy kWh	1.0.1.8.0.255	3 / 2
xxv)	Cumulative Energy kvarh Lag	1.0.5.8.0.255	3 / 2
xxvi)	Cumulative Energy kvarh Lead	1.0.8.8.0.255	3 / 2

xxvii) Cumulative Energy kVAh

1.0.9.8.0.255

3 / 2

NOTES

- 1) The items at SI No v), vi) and vii) are for 3Φ / 4W system of measurement with NEUTRAL as reference point.
- 2) The items at SI No viii) and ix) are for 3 Φ / 3W system of measurement with Y-PHASE as reference point.
- 3) Signed Power factor – (+ indicates lag) and (- indicates lead).
- 4) The parameters at SI No xviii) to xxii) hold cumulative values at that instant from the date of manufacturing or installation of meter as the case may be.
- 5) The above list is identified for the purpose of communication to HOST or HHU.
- 6) The utilities may choose, based on needs, additional parameters for display purpose ONLY.
- 7) Item at SI No xxi) refers to the Billing Period Counter
- 8) Item at SI No xxiii) - Data type to be same as for attribute 2 of IC 8, Clock.

E-3.2 Scaler Profile

This profile is meant for capturing the Scaler-unit of each of the parameter listed in Table 27. This is modeled as profile generic (IC=7) and is assigned the country specific OBIS code 1.0.94.91.3.255. The capture objects for this profile shall include the scaler-unit attributes of the Instantaneous parameters listed above. Instantaneous parameters that do not have a scaler-unit (like IC 1) shall not be included in the capture objects list. The profile buffer shall have only one entry. This profile is not required to be updated periodically.

E-4 BLOCK LOAD PROFILE PARAMETERS

This is an array of load survey data captured as a profile generic. The OBIS code is 1.0.99.1.0.255, with Interface class as 7. The capture objects of this block load profile are as per Table 28 and the captured attribute shall be 2 of each interface class. The capture object values will be copied into a buffer of this array automatically as per capture period which shall be set through OBIS code 1.0.0.8.4.255 of recording interval 1.

Association Access Rights are as follows:

- a) Public Client – No access for all objects.
- b) Meter Reader – Read only for all objects.
- c) Utility Setting – Read only for all objects.

Table 28 Block Load Survey Parameters for Class C Meters
(Clause E-2 & E-4)

SI No	Parameter	OBIS Code	Interface Class No / Attribute
(1)	(2)	A.B.C.D.E.F (3)	(4)

i)	Real Time Clock – Date and Time	0.0.1.0.0.255	8 / 2
ii)	Current - IR	1.0.31.27.0.255	3 / 2
iii)	Current – IY	1.0.51.27.0.255	3 / 2
iv)	Current – IB	1.0.71.27.0.255	3 / 2
v)	Voltage – VRN	1.0.32.27.0.255	3 / 2
vi)	Voltage – VYN	1.0.52.27.0.255	3 / 2
vii)	Voltage – VBN	1.0.72.27.0.255	3 / 2
viii)	Voltage – VRY	1.0.32.27.0.255	3 / 2
ix)	Voltage – VBY	1.0.52.27.0.255	3 / 2
x)	Block Energy – kWh	1.0.1.29.0.255	3 / 2
xi)	Block Energy – kvarh – lag	1.0.5.29.0.255	3 / 2
xii)	Block Energy – kvarh – lead	1.0.8.29.0.255	3 / 2
xiii)	Block Energy – kVAh	1.0.9.29.0.255	3 / 2

NOTES

- 1) The parameters listed in this table are for load survey purpose and are logged as per the block period time.
- 2) The parameters at SI No ii) to ix) are the average values during the block period time and stored at the end of that time block.
- 3) The parameters at SI No x) to xiii) are the actual energy consumption during that time block.
- 4) Capture objects for 3 Φ / 4W are items at SI No i) to vii) and x) to xiii)
- 5) Capture objects for 3 Φ / 3W are items at SI No i) to iv) and viii) to xiii)
- 6) Support for Selective access shall be as defined in Section 11.3

E-4.1 Scaler Profile

This profile is meant for capturing the Scaler-unit of each of the parameter listed in Table 28. This is modeled as profile generic (IC=7) and is assigned the country specific OBIS code 1.0.94.91.4.255. The capture objects for this profile shall include the scaler-unit attributes of the parameters listed above. The profile buffer shall have only one entry. This profile is not required to be updated periodically.

E-5 BILLING PROFILE PARAMETERS

The contents of this table are for billing purpose.

Association Access Rights are as follows:

- a) Public Client – No access for all objects.
- b) Meter Reader – Read only for all objects.
- c) Utility Setting – Read only for all objects.

Table 29 Billing Profile Parameters for Class C Meters

S.No	Parameter	OBIS Code A.B.C.D.E.F	Interface Class No / Attribute
(1)	(2)	(3)	(4)
i)	Billing Date	0.0.0.1.2.255	3 / 2
ii)	System Power Factor for Billing Period	1.0.13.0.0.255	3 / 2
iii)	Cumulative Energy – kWh	1.0.1.8.0.255	3 / 2
iv)	Cumulative Energy – kWh – TZ1	1.0.1.8.1.255	3 / 2
v)	Cumulative Energy – kWh – TZ2	1.0.1.8.2.255	3 / 2
vi)	Cumulative Energy – kWh – TZ3	1.0.1.8.3.255	3 / 2
vii)	Cumulative Energy – kWh – TZ4	1.0.1.8.4.255	3 / 2
viii)	Cumulative Energy – kWh – TZ5	1.0.1.8.5.255	3 / 2
ix)	Cumulative Energy – kWh – TZ6	1.0.1.8.6.255	3 / 2
x)	Cumulative Energy – kWh – TZ7	1.0.1.8.7.255	3 / 2
xi)	Cumulative Energy – kWh – TZ8	1.0.1.8.8.255	3 / 2
xii)	Cumulative Energy – kvarh – Lag	1.0.5.8.0.255	3 / 2
xiii)	Cumulative Energy – kvarh – Lead	1.0.8.8.0.255	3 / 2
xiv)	Cumulative Energy – kVAh	1.0.9.8.0.255	3 / 2

xv)	Cumulative Energy – kVAh – TZ1	1.0.9.8.1.255	3 / 2
xvi)	Cumulative Energy – kVAh – TZ2	1.0.9.8.2.255	3 / 2
xvii)	Cumulative Energy – kVAh – TZ3	1.0.9.8.3.255	3 / 2
xviii)	Cumulative Energy – kVAh – TZ4	1.0.9.8.4.255	3 / 2
xix)	Cumulative Energy – kVAh – TZ5	1.0.9.8.5.255	3 / 2
xx)	Cumulative Energy – kVAh – TZ6	1.0.9.8.6.255	3 / 2
xxi)	Cumulative Energy – kVAh – TZ7	1.0.9.8.7.255	3 / 2
xxii)	Cumulative Energy – kVAh – TZ8	1.0.9.8.8.255	3 / 2
xxiii)	MD – kW	1.0.1.6.0.255	4 / 2 ,5
xxiv)	MD – kW – TZ1	1.0.1.6.1.255	4 / 2 ,5
xxv)	MD – kW – TZ2	1.0.1.6.2.255	4 / 2 ,5
xxvi)	MD – kW – TZ3	1.0.1.6.3.255	4 / 2 ,5
xxvii)	MD – kW – TZ4	1.0.1.6.4.255	4 / 2 ,5
xxviii)	MD – kW – TZ5	1.0.1.6.5.255	4 / 2 ,5
xxix)	MD – kW – TZ6	1.0.1.6.6.255	4 / 2 ,5
xxx)	MD – kW – TZ7	1.0.1.6.7.255	4 / 2 ,5
xxxi)	MD – kW – TZ8	1.0.1.6.8.255	4 / 2 ,5
xxxii)	MD – kVA	1.0.9.6.0.255	4 / 2 ,5
xxxiii)	MD – kVA – TZ1	1.0.9.6.1.255	4 / 2 ,5
xxxiv)	MD – kVA – TZ2	1.0.9.6.2.255	4 / 2 ,5
xxxv)	MD – kVA – TZ3	1.0.9.6.3.255	4 / 2 ,5
xxxvi)	MD – kVA – TZ4	1.0.9.6.4.255	4 / 2 ,5

xxxvii)	MD – kVA – TZ5	1.0.9.6.5.255	4 / 2 ,5
.xxviii)	MD – kVA – TZ6	1.0.9.6.6.255	4 / 2 ,5
xxxix)	MD – kVA – TZ7	1.0.9.6.7.255	4 / 2 ,5
xl)	MD – kVA – TZ8	1.0.9.6.8.255	4 / 2 ,5

NOTES

- 1) The data are stored up to 6 billing cycles. The Billing profile is modeled as Profile generic (IC: = 7) object with OBIS Code 1.0.98.1.0.255. The capture objects of this load profile are as per Table-29. The capture object values will be copied into buffer of this object either automatically or asynchronously. The capture period is set to zero, billing action is controlled by billing dates as provided in 10 and table 31.
- 2) Support for Selective access shall be as defined in Section 11.3
- 3) The current cycle billing parameters shall be readable as the values of the latest billing period, on demand. This shall be in addition to the last 6 billing period data which shall be available in the Profile buffer as the last 6 entries in the buffer.
- 4) The captured attributes in case of Interface Class 4 (Extended register) used for MD values will be attributes 2 and 5 (Value and Timestamp)

E-5.1 Scaler Profile

This profile is meant for capturing the Scaler-unit of each of the parameter listed in Table 29. This is modeled as profile generic (IC=7) and is assigned the country specific OBIS code 1.0.94.91.6.255. The capture objects for this profile shall include the scaler-unit attributes of the parameters listed above. The profile buffer shall have only one entry. This profile is not required to be updated periodically.

ANNEX F
(Clause A-5)

GENERAL PURPOSE PARAMETERS

F-1 NAME PLATE DETAILS

The contents of Table 30 are common to all meters. The data are meter specific information.

Association Access Rights for Name Plate Details are as follows:

- a) Public Client – No access for all objects except Meter Serial number.
- b) Meter Reader – Read only for all objects.
- c) Utility Setting – Read only for all objects.

:

Table 30 Name Plate Details Parameters
(Clause F-1)

SI No	Parameter	OBIS Code A.B.C.D.E.F	Interface Class
(1)	(2)	(3)	(4)
i)	Meter Serial Number	0.0.96.1.0.255	1 (Data)
ii)	Manufacturer name	0.0.96.1.1.255	1
iii)	Firmware Version for meter	1.0.0.2.0.255	1
iv)	Meter type (3P-3W / 3P-4W)	0.0.94.91.9.255	1
v)	Internal CT ratio	1.0.0.4.2.255	1
vi)	Internal PT ratio	1.0.0.4.3.255	1
vii)	Meter year of manufacture	0.0.96.1.4.255	1

NOTE For item SI No iv), a value of “0” indicates 3P-3W; a value of “1” indicates 3P-4W

F-2 Programmable Parameters.

Association Access Rights for programmable parameters as given in Table 31 are as follows:

- a) Public Client – No Access for all objects except Real Time Clock.
- b) Meter Reader – Read only for all objects.
- c) Utility Setting – Read, Write for all objects.

Table 31 Programmable Parameters
(Clause F-2)

SI No	Parameter	OBIS Code A.B.C.D.E.F	Interface Class
(1)	(2)	(3)	(4)
i)	Real Time Clock – Date and Time	0.0.1.0.0.255	8 (Clock)
ii)	Demand Integration Period	1.0.0.8.0.255	1 (Data)
iii)	Profile Capture Period	1.0.0.8.4.255	1
iv)	Single-action Schedule for Billing Dates	0.0.15.0.0.255	22
v)	Activity Calendar for Time Zones etc.	0.0.13.0.0.255	20

NOTES

- 1) The parameters are programmable by the utility engineers with required access rights.
- 2) Unit for Demand Integration Period and profile capture period is in “seconds”.
- 3) Programming of any of the parameters shall increment the “Cumulative programming count” value.

ANNEX G*(Clause A-6)***EVENT REFERENCE TABLE****G-1 EVENTS**

Any exceptional / fraud / tamper condition is considered as an Event and stored in an Event code object (OBIS: = 0.0.96.11.e.255 IC: = 1, values of E range from 0 to 6). The value attribute (attr-2) of this object stores identifier corresponding to most recent event occurred in the meter. Unique identifier is assigned to occurrence and restoration of all possible events (identified so far) in the event reference tables (Table 32 to 38). Thus event code object will tell only about the most recent event and to get a picture of all events and associated information (at the time of event) an Event log object is used. An event log object is modeled as Profile generic (OBIS: = 0.0.99.98.e.255 IC: = 7, values of E range from 0 to 6). The buffer attribute (attr-2) of this profile object will store (asynchronously) a new entry for every event (occurrence and restoration are considered as separate events). The capture objects for the event log object is define below in Table-39.

G-1.1 Indian Event Reference Tables

The contents of Table 32 to 38 are common to all categories of meter for which the parameters are selected as per the category of meter.

Table 32 Indian Event Reference Table – Voltage Related
(Clause G-1 & G-1.1)

Sl No	Event ID	Descriptions
(1)	(2)	(3)
i)	1	R-Phase – PT link Missing (Missing Potential) – Occurrence
ii)	2	R-Phase – PT link Missing (Missing Potential) – Restoration
iii)	3	Y-Phase – PT link Missing (Missing Potential) – Occurrence
iv)	4	Y-Phase – PT link Missing (Missing Potential) – Restoration
v)	5	B-Phase – PT link Missing (Missing Potential) – Occurrence
vi)	6	B-Phase – PT link Missing (Missing Potential) – Restoration
vii)	7	Over Voltage in any Phase - Occurrence
viii)	8	Over Voltage in any Phase - Restoration
ix)	9	Low Voltage in any Phase - Occurrence
x)	10	Low Voltage in any Phase - Restoration
xi)	11	Voltage Unbalance - Occurrence
xii)	12	Voltage Unbalance - Restoration

Table 33 Indian Event Reference Table – Current Related
(Clause G-1 & G-1.1)

SI No	Event ID	Descriptions
(1)	(2)	(3)
i)	51	Phase – R CT reverse – Occurrence
ii)	52	Phase – R CT reverse – Restoration
iii)	53	Phase – Y CT reverse – Occurrence
iv)	54	Phase – Y CT reverse – Restoration
v)	55	Phase – B CT reverse – Occurrence
vi)	56	Phase – B CT reverse – Restoration
vii)	57	Phase – R CT Open - Occurrence
viii)	58	Phase – R CT Open - Restoration
ix)	59	Phase – Y CT Open - Occurrence
x)	60	Phase – Y CT Open - Restoration
xi)	61	Phase – B CT Open - Occurrence
xii)	62	Phase – B CT Open - Restoration
xiii)	63	Current Unbalance - Occurrence
xiv)	64	Current Unbalance - Restoration
xv)	65	CT Bypass – Occurrence
xvi)	66	CT Bypass – Restoration
xvii)	67	Over Current in any Phase – Occurrence
xviii)	68	Over Current in any Phase – Restoration

Table 34 Indian Event Reference Table – Power Related
(Clause G-1 & G-1.1)

SI No	Event ID	Descriptions
(1)	(2)	(3)
i)	101	Power failure (3 phase) – Occurrence
ii)	102	Power failure (3 phase) – Restoration

Table 35 Indian Event Reference Table – Transaction Related
(Clause G-1 & G-1.1)

SI No	Event ID	Descriptions
(1)	(2)	(3)
i)	151	Real Time Clock – Date and Time
ii)	152	Demand Integration Period
iii)	153	Profile Capture Period
iv)	154	Single-action Schedule for Billing Dates
v)	155	Activity Calendar for Time Zones etc.

Table 36 Indian Event Reference Table – Others
(Clause G-1 & G-1.1)

Sl No	Event ID	Descriptions
(1)	(2)	(3)
i)	201	Influence of Permanent Magnet or AC/ DC Electromagnet - Occurrence
ii)	202	Influence of Permanent Magnet or AC/ DC Electromagnet - Restoration
iii)	203	Neutral Disturbance - HF & DC - Occurrence
iv)	204	Neutral Disturbance - HF & DC - Restoration
v)	205	Very Low PF - Occurrence
vi)	206	Very Low PF - Restoration

Table 37 Indian Event Reference Table – Non Roll Over Events
(Clause G-1 & G-1.1)

Sl.No.	Event ID	Descriptions
(1)	(2)	(3)
i)	251	Meter Cover Opening – Occurrence

Table 38 Indian Event Reference Table – Control Events
(Clause G-1.1)

Sl No	Event ID	Descriptions
(1)	(2)	(3)
i)	301	Meter disconnected
ii)	302	Meter connected

G-1.2 Capture Parameters For Event As Applicable (Event Log Profile)

Association Access Rights are as follows:

- a) Public Client - No access
- b) Meter Reading - Read only
- c) Utility Settings - Read only

Table 39 Capture Parameters for Events
(Clause G-1)

SI No	Parameter	A	B	C	D	E	F	IC
(1)	(2)	(3)	(4)	(5)	(6)	(7)	(8)	(9)
i)	Date and Time of event	0	0	1	0	0	255	8 (Clock)
ii)	Event Code	0	0	96	11	0	255	1 (Data)
iii)	Current - IR	1	0	31	7	0	255	3 (Register)
iv)	Current - IY	1	0	51	7	0	255	3 (Register)
v)	Current – IB	1	0	71	7	0	255	3 (Register)
vi)	Voltage - VRN (3 Φ / 4W)	1	0	32	7	0	255	3 (Register)
vii)	Voltage – VYN (3 Φ / 4W)	1	0	52	7	0	255	3 (Register)
viii)	Voltage – VBN (3 Φ / 4W)	1	0	72	7	0	255	3 (Register)
ix)	Voltage - VRX (3 Φ / 3W)	1	0	32	7	0	255	3 (Register)
x)	Voltage – VYB (3 Φ / 3W)	1	0	52	7	0	255	3 (Register)
xi)	Power Factor – R phase	1	0	33	7	0	255	3 (Register)
xii)	Power Factor – Y phase	1	0	53	7	0	255	3 (Register)
xiii)	Power Factor – B phase	1	0	73	7	0	255	3 (Register)
xiv)	Cumulative Energy – kWh	1	0	1	8	0	255	3 (Register)

G-1.3 Note For Tables (32,33,34,35,36,37,38 and 39)

- 1) These are the event conditions generally recorded in consumer meters, utilities may select any the above event conditions based on their practice. The need and applicability of these events for other type of meters shall be considered by Utility.
- 2) Either Occurrence or Restoration is considered an event.
- 3) For each of the events a certain list of parameters will be captured.
- 4) The list capture parameters are given in Table 39. The utility shall select the required parameters from the Table 39 as per their practice.
- 5) For each of the event captured “Cumulative tamper count” value will be incremented except for events from Tables 34, 35, 37 and 38.
- 6) Capture parameters mentioned in Table 39 are captured when event occurrence and restoration is logged.
- 7) For events in Table 34, 38 no parameters shall be captured along with the event.
- 8) The attributes of each of the IC (Interface Class) is to be identified while finalizing the Companion Standard.
- 9) For 3 Φ / 4W the reference point is NEUTRAL
- 10) For 3 Φ / 3W the reference point is Y-Phase
- 11) Support for Selective access shall be as defined in Section 11.3

G-2 Scaler Profile

This profile is meant for capturing the Scaler-unit of each of the parameter listed in Table 39. This is modeled as profile generic (IC=7) and is assigned the country specific OBIS code 1.0.94.91.7.255. The capture objects for this profile shall include the scaler-unit attributes of the parameters listed above. Parameters listed above that do not have a scaler-unit attribute shall not be included in the capture objects of this profile. The profile buffer shall have only one entry. This profile is not required to be updated periodically.

ANNEX H

(*Clause 3.1.23*)

CONFORMANCE TESTING

H-1 Meters claiming conformance to this Companion Specification will be required to

- a) Conform to the DLMS/COSEM base standards (IEC 62056.) as certified by the conformance test tool (CTT)
- b) Conform to the specific requirements and constraints of this companion specification as certified by CPRI or any other laboratory having facilities for the purpose.

H-2 This certification shall ensure

- a) All mandatory parameters applicable to the category of the meter under test are implemented
- b) All data types where specified are conforming to this document
- c) All Application Associations are implemented as specified in this document with all specified services supported
- d) Association object lists conform to this document with access rights and OBIS codes as specified here
- e) Event related DLMS objects are implemented with Event identifiers as specified in the Event reference tables in this document

H-2.1 The test report from an accredited laboratory and having membership with DLMS UA shall be considered as a proof of conformance of protocol implementation.

H-2.2 Systems once created in accordance with this companion specification and contemporary standards, shall be deemed acceptable, provided such systems are tested and certified through standard evaluation process.

ANNEX J
(Clause 1.3 & 3.1.6)

HHU (MRI) CONSIDERATION

J-1 HHU (MRI) CONSIDERATION

Communication standards in the Indian metering scenario require supporting considerations for the utilization of those standards in HHUs (Hand held units synonymous with MRI or CMRI). This annex provides a suitable approach to the implementation of the IEC-62056 standards and this Indian Companion Specification in such devices.

J-1.1 The terms of this suggested implementation are as below

- a) HHUs may retrieve data from DLMS/COSEM Meters conforming to this standard using the communication ports.
- b) HHUs shall exclusively use the Meter Reading association (MR) and shall support all the features and specifications listed in this specification for the MR Association
- c) HHUs shall have the same data access rights that are available to the MR Association, as that available for remote meter reading.
- d) HHU when acting as a server shall support the client addresses and security methods of the Meter Reading (MR) Association
- e) HHUs shall provide a DLMS/COSEM server interface to the BCS (Base Computer System – the Data collection software) over a suitable communication medium (local serial port implementing the DLMS/COSEM CO 3-layer stack is suggested)
- f) HHUs shall internally map the individual meter data to Logical Devices (one Logical Device for each meter). Inside each Logical Device the structure and naming of the data shall be the same as that retrieved from the meter
- g) For each logical device the DLMS/COSEM server shall support one association with properties, objects, and access rights adequate for transferring the stored data of the corresponding meter to the BCS in an efficient manner. The server within the HHU is not required to support ad-hoc access or selective access to the data that differs from the requests which were earlier used to read the data from the meter.
- h) The BCS shall maintain a mapping table that maps the individual meter identifications (the same IDs that are used to identify the meter during remote meter reading) to Logical Device addresses. During upload of data from HHU to BCS, the BCS shall query each Logical device to download the data of each meter over the local serial port
- i) The mapping table described in Item I-1.6 above shall require that the Logical device addresses allocated to each meter are at least unique across all meters that are to be retrieved using one HHU. Other HHUs may re-use the same addressing from their own range of allocated meters. The BCS shall take care to ensure that the re-use of addresses does not create conflicts in Meter identification.

ANNEX K
(Clause 11.3.5)

DESCRIPTIVE NOTES ON PROFILE GENERIC INTERFACE CLASS

K-1 Profile Generic objects are available to capture values of attributes from other objects periodically or occasionally. They can be used:

- a) For load profiles
- b) For historical data
- c) For event logs etc.

K-1.1 The list of attributes to capture are held by the capture object attribute. The values captured are held in the buffer attribute.

K-1.2 The buffer can be seen as a table, with the capture objects as column headers and a new line of values added with each capture. The data in the buffer can be accessed in its entirety or selectively, using appropriate selection criteria.

K-1.3 Profile generic objects provide attributes and methods for controlling and managing how data are captured and accessed as illustrated in Fig. 3.

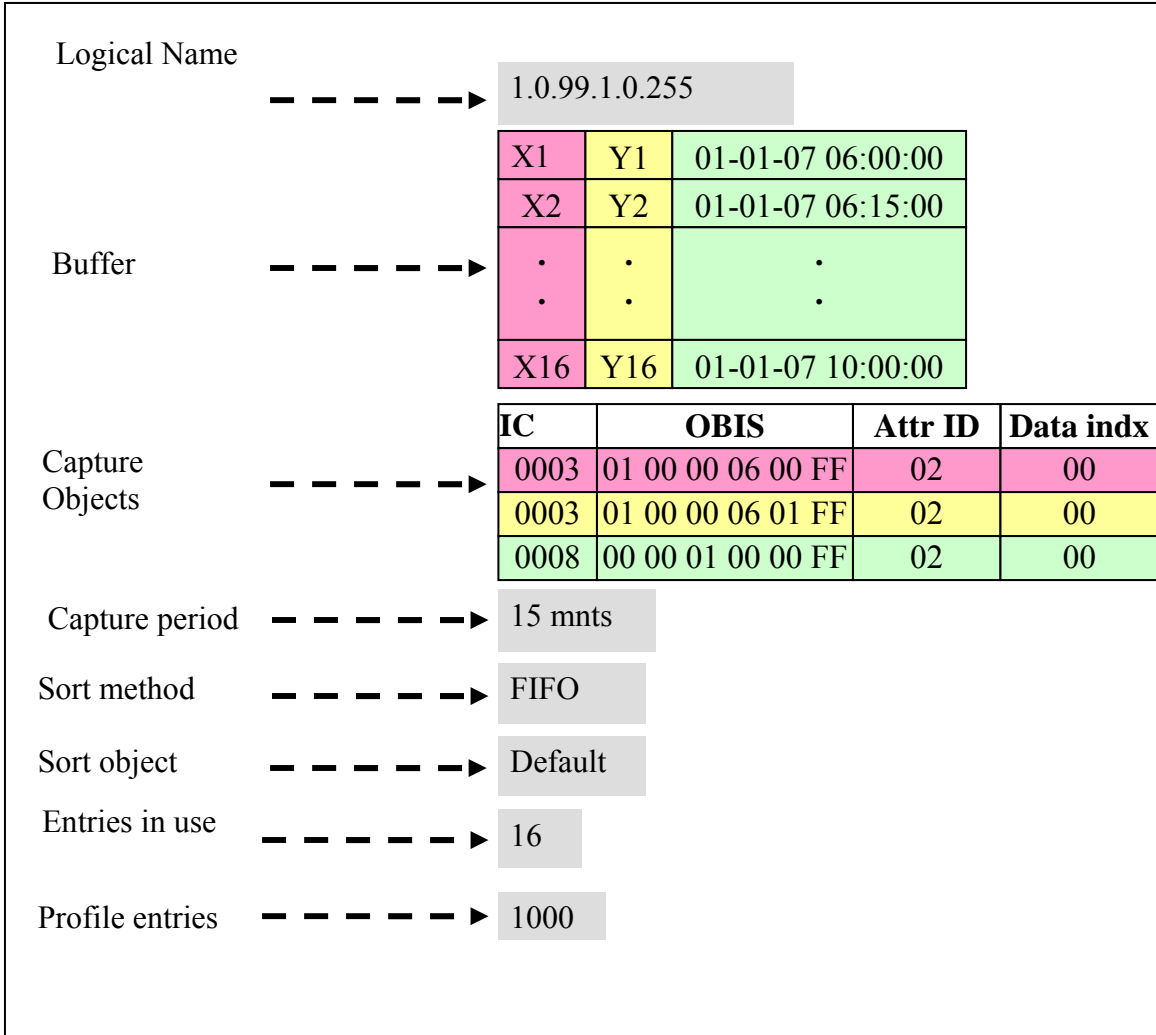

Fig 3 ILLUSTRATION OF A PROFILE GENERIC OBJECT CONTAINING 16 CAPTURES OF 3 ATTRIBUTES

K-2 SELECTIVE ACCESS

There are two types of selective access which allows reading the buffer selectively.

K-2.1 Selective Access by Entry

Selective Access by Entry provides a set of 4 integers to filter the contents of the “buffer” attribute in response to get requests as illustrated in Fig. 4. The 4 integers are as below

- a) From-entry: The index of the first entry to return from the buffer
- b) To-Entry: The index of the last entry to return from the buffer
- c) From-Value: The index of the first column to return
- d) To-Value: The index of the last column to return

Thus the selective access parameters as above can be used to select a subset of the rows from the buffer table.

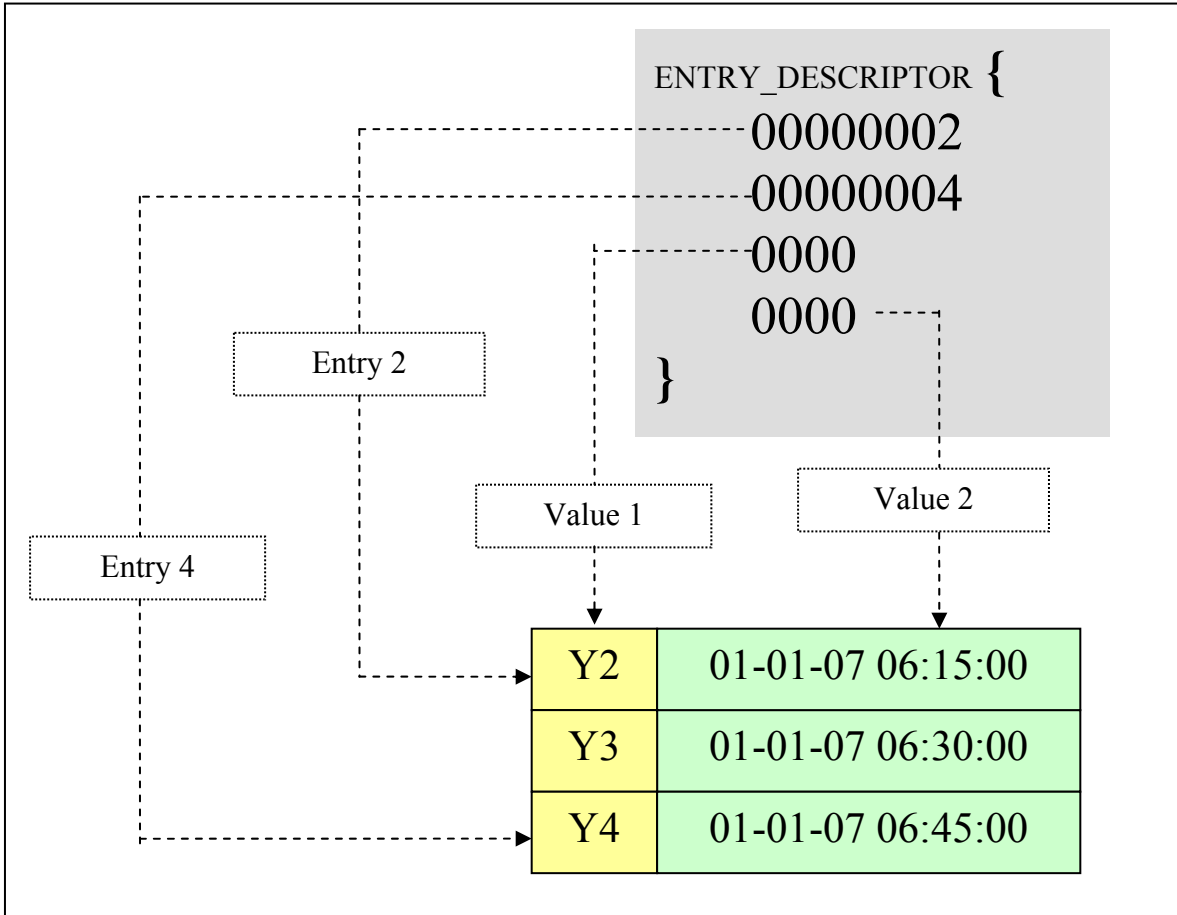

Fig 4 ILLUSTRATION OF SELECTIVE ACCESS OF PROFILE BUFFER BY ENTRY. THIS ILLUSTRATION REQUESTS FROM 2ND ROW TO THE 4TH ROW.

K-2.2 Selective Access by Range

Selective Access by Range permits a client to retrieve a subset of the rows and columns in the Profile buffer based on the value of one of the capture objects. Typically the capture object selected for this purpose is the Clock's date-time attribute which is usually one of the capture objects in most profiles as illustrated in Fig. 5. The selective access parameters in this case are as below.

K-2.2.1 Restricting object

This parameter identifies the capture object whose value will be used to filter the buffer. The object is defined by the OBIS code and attribute index of the selected object.

K-2.2.2 From-Value

The start-range value for the subset. All selected rows in the buffer will have a value for the restricted object that is higher than or equal to this limit.

K-2.2.3 To-Value

The stop-range value for the subset. All selected rows in the buffer will have a value for the restricting object that is lower than or equal to this limit.

K-2.2.4 Selected-Values

An array of column indices specifying the columns that should be returned from the selected rows.

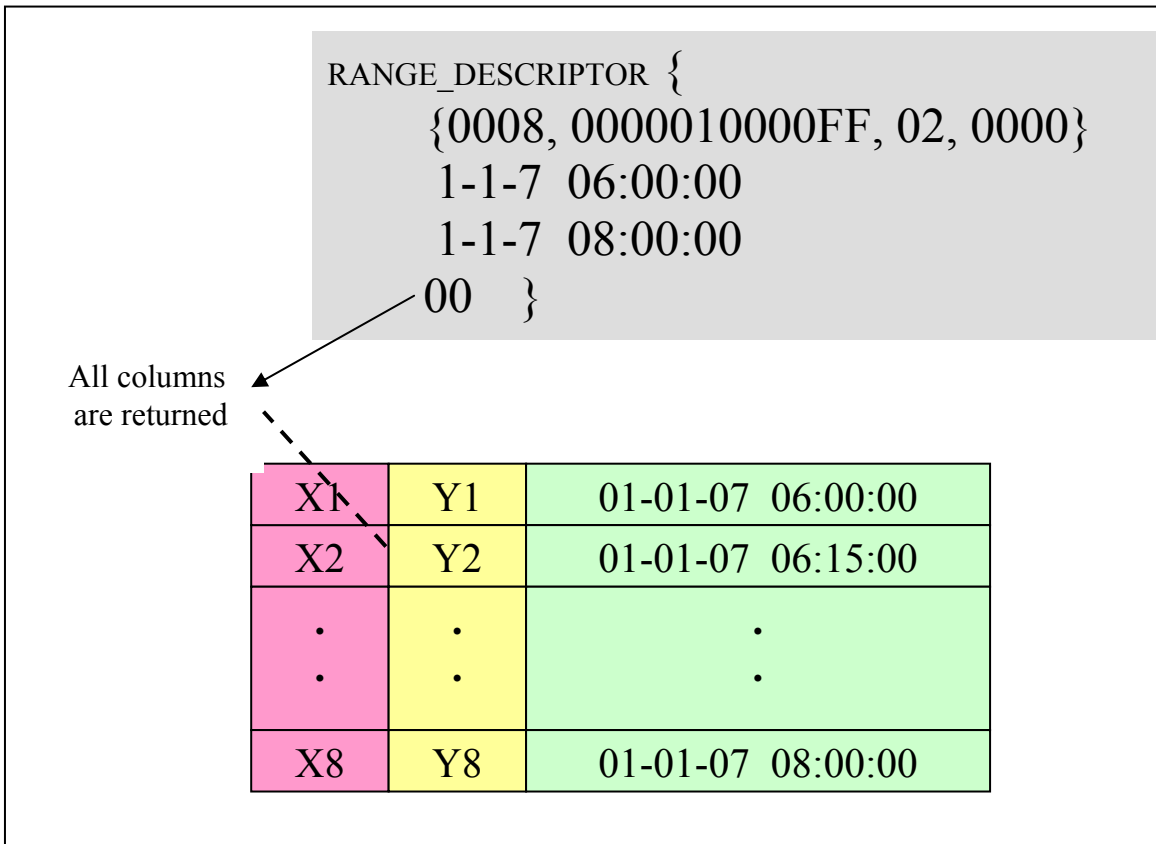

Fig 5 ILLUSTRATION OF SELECTIVE ACCESS OF PROFILE BUFFER BY RANGE

ANNEX L
(Foreword)

<i>Abbreviation</i>	<i>Description</i>
IEC	International Electro technical Commission
NIST	National Institute for Standards and Technology
IETF	Internet Engineering Task Force
HHU	Hand Held Unit
MRI	Meter Reading Instrument
DCE	Data Communication Equipment
DC	Data Concentrator
PSTN	Public Switched Telephone Network
GSM	Global System for Mobile Communications
GPRS	General Packet Radio Service
802.2 LLC	ISO/ IEC 8802-2 defined Logical Link Control
IEEE	Institute of Electrical and Electronics Engineers
ASE	Adaptive Server Enterprise for database security

ZigBee	Low power wireless connectivity based on IEEE standard 802.15.4 protocol
VZ	VorwärtsZaehler: (previous value counter).
IP	Internet Protocol
PC	Public Client
MR	Meter Reader
US	Utility Settings
TCP	Transmission Control Protocol (for connection oriented service)
UDP	User Datagram Protocol (for connectionless service)
RS232 / RS485	Recommended industrial Standards for communication between driver and receiver equipment.
TOU	Time of Use
ABT	Availability Based Tariff
CTT	Conformance Test Tool
